

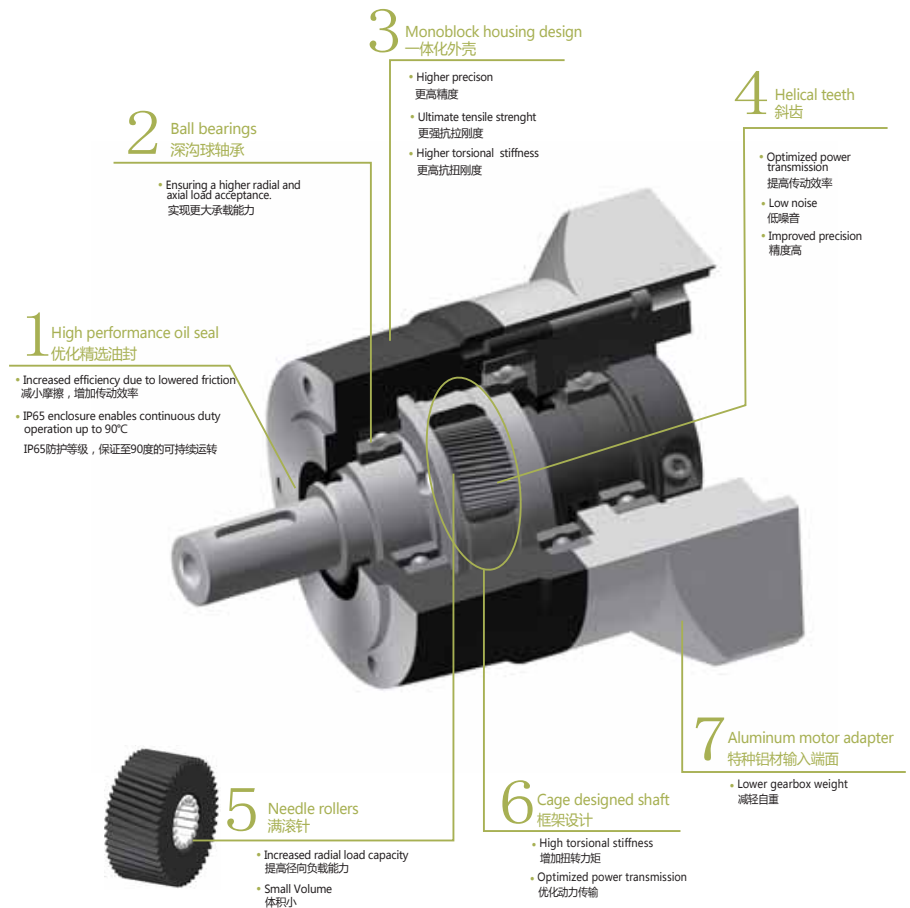

此标准系列可以在中等精度要求的不同领域使用。

Standard series for servo applications that do not require optimum precision.



**造型数据:**

**Selection data:**

扭矩 ( Nm )	8-180
速比	3-100
背隙 ( arcmin )	5-8
最大工作温度 ( °C )	90
噪音 ( dB )	64-75

Nominal output torque ( Nm )	8-180
Reduction ratio	3-100
Backlash ( arcmin )	5-8
Max.working temperature ( °C )	90
Noise ( dB )	64-75

MPE-040-L1

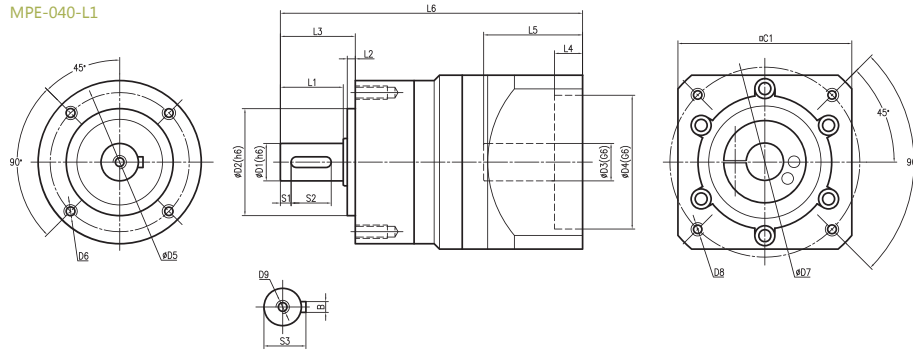

Flange	D1	D2	D3*	D4*	D5	D6	D7*	D8*	D9	L1	L2	L3	L4*	L5*	L6	C1*	S1	S2	S3	B
Type I	Φ12	Φ26	Φ8	Φ30	Φ34	4-M4X8	Φ46	4-M4X10	M4X10	18	2	21.5	5	32	88	40	2	14	13.5	4
Type II	Φ12	Φ26	Φ11	Φ50	Φ34	4-M4X8	Φ70	4-M4X10	M4X10	18	2	21.5	5	32	88	60	2	14	13.5	4

MPE-060-L1

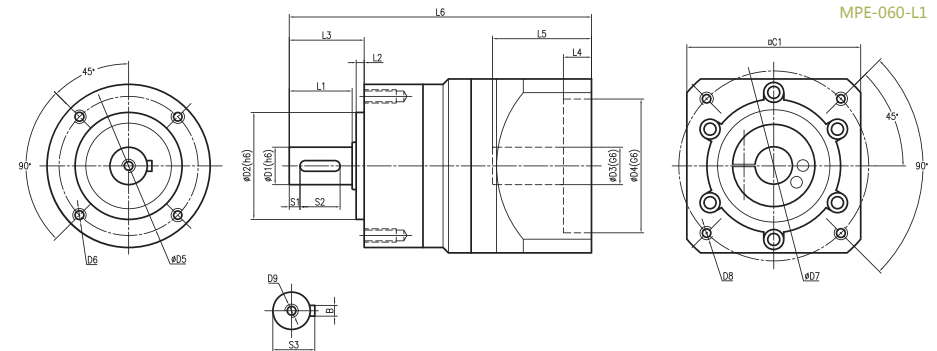

Flange	D1	D2	D3*	D4*	D5	D6	D7*	D8*	D9	L1	L2	L3	L4*	L5*	L6*	C1*	S1	S2	S3	B
Type I	Φ14	Φ40	Φ11	Φ50	Φ52	4-M5X10	Φ70	4-M4X10	M5X13	23.5	3	28	10.5	37	113	65	4	15	15.7	4
Type II	Φ14	Φ40	Φ14	Φ50	Φ52	4-M5X10	Φ70	4-M5X12	M5X13	23.5	3	28	10.5	37	113	65	4	15	15.7	4

MPE-040-L2

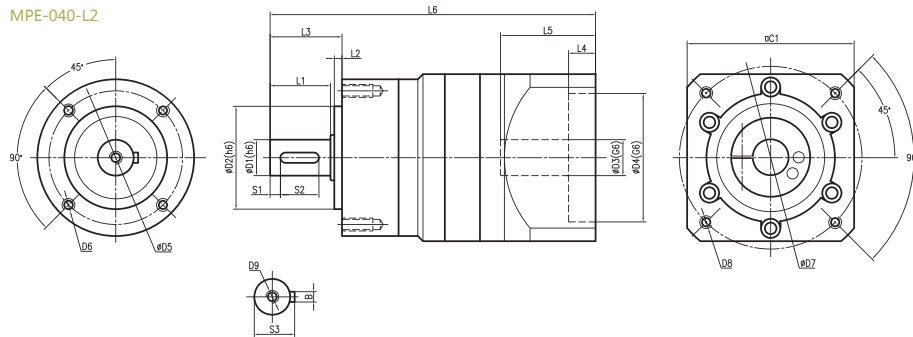

Flange	D1	D2	D3*	D4*	D5	D6	D7*	D8*	D9	L1	L2	L3	L4*	L5*	L6*	C1*	S1	S2	S3	B
Type I	Φ12	Φ26	Φ8	Φ30	Φ34	4-M4X8	Φ46	4-M4X10	M4X10	18	2	21.5	5	32	104.5	40	2	14	13.5	4
Type II	Φ12	Φ26	Φ8	Φ30	Φ34	4-M4X8	Φ45	4-M4X10	M4X10	18	2	21.5	5	32	104.5	40	2	14	13.5	4

MPE-060-L2

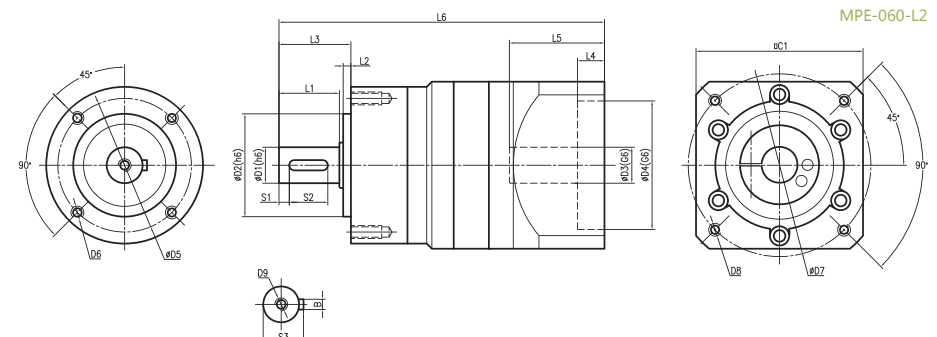

Flange	D1	D2	D3*	D4*	D5	D6	D7*	D8*	D9	L1	L2	L3	L4*	L5*	L6*	C1*	S1	S2	S3	B
Type I	Φ14	Φ40	Φ11	Φ50	Φ52	4-M5X10	Φ70	4-M4X10	M5X13	23.5	3	28	10.5	37	133	65	4	15	15.7	4
Type II	Φ14	Φ40	Φ14	Φ50	Φ52	4-M5X10	Φ70	4-M5X12	M5X13	23.5	3	28	10.5	37	133	65	4	15	15.7	4

\*Dimensions based on servo-motor, please contact us for custom made order.  
注有 \* 尺寸：代表可根据客户需求定制产品，如有需要，请联系我们！

\*Dimensions based on servo-motor, please contact us for custom made order.  
注有 \* 尺寸：代表可根据客户需求定制产品，如有需要，请联系我们！

MPE-090-L1

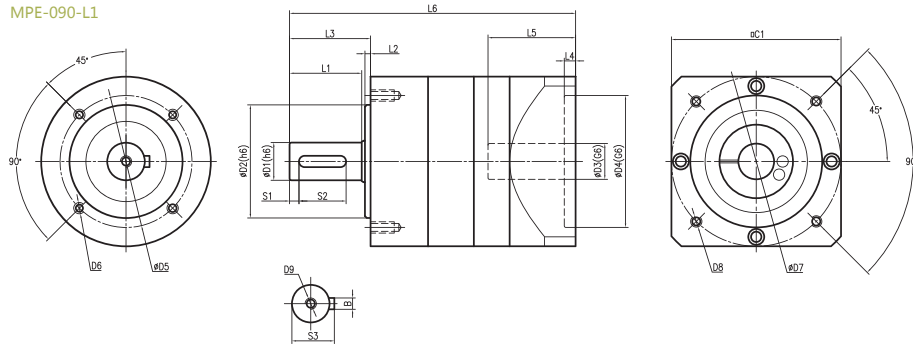

Flange	D1	D2	D3*	D4*	D5	D6	D7*	D8*	D9	L1	L2	L3	L4*	L5*	L6*	C1*	S1	S2	S3	B
Type I	Φ20	Φ60	Φ14	Φ50	Φ70	4-M6X12	Φ70	4-M5X12	M6X15	39	3	43	5	37	148.3	65	5	25	22.5	6
Type II	Φ20	Φ60	Φ19	Φ70	Φ70	4-M6X12	Φ90	4-M6X15	M6X15	39	3	43	6	46.5	151.8	90	5	25	22.5	6
Type III	Φ20	Φ60	Φ22	Φ110	Φ70	4-M6X12	Φ145	4-M8X15	M6X15	39	3	43	6	46.5	151.8	130	5	25	22.5	6
Type IV	Φ20	Φ60	Φ24	Φ110	Φ70	4-M6X12	Φ145	4-M8X15	M6X15	39	3	43	6	46.5	151.8	130	5	25	22.5	6

MPE-120-L1

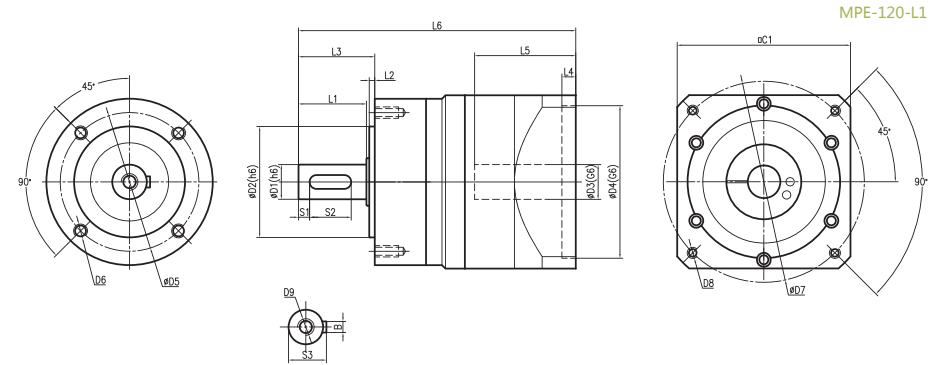

Flange	D1	D2	D3*	D4*	D5	D6	D7*	D8*	D9	L1	L2	L3	L4*	L5*	L6*	C1*	S1	S2	S3	B
Type I	Φ25	Φ80	Φ19	Φ70	Φ100	4-M10X20	Φ90	4-M5X12	M10X24	50	4	55	5	38.5	172	80	8	30	28	8
Type II	Φ25	Φ80	Φ22	Φ110	Φ100	4-M10X20	Φ145	4-M8X15	M10X24	50	4	55	11.5	63	192	125	8	30	28	8
Type III	Φ25	Φ80	Φ24	Φ110	Φ100	4-M10X20	Φ145	4-M8X15	M10X24	50	4	55	11.5	63	192	125	8	30	28	8

MPE-090-L2

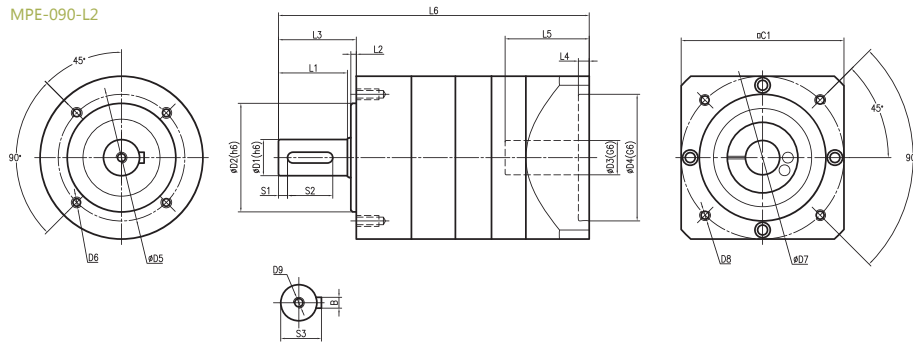

Flange	D1	D2	D3*	D4*	D5	D6	D7*	D8*	D9	L1	L2	L3	L4*	L5*	L6*	C1*	S1	S2	S3	B
Type I	Φ20	Φ60	Φ14	Φ50	Φ70	4-M6X12	Φ70	4-M5X12	M6X15	39	3	43	5	37	163.3	65	5	25	22.5	6
Type II	Φ20	Φ60	Φ19	Φ70	Φ70	4-M6X12	Φ90	4-M6X15	M6X15	39	3	43	6	46.5	179.3	90	5	25	22.5	6
Type III	Φ20	Φ60	Φ22	Φ110	Φ70	4-M6X12	Φ145	4-M8X15	M6X15	39	3	43	6	46.5	179.3	130	5	25	22.5	6
Type IV	Φ20	Φ60	Φ24	Φ110	Φ70	4-M6X12	Φ145	4-M8X15	M6X15	39	3	43	6	46.5	179.3	130	5	25	22.5	6

MPE-120-L2

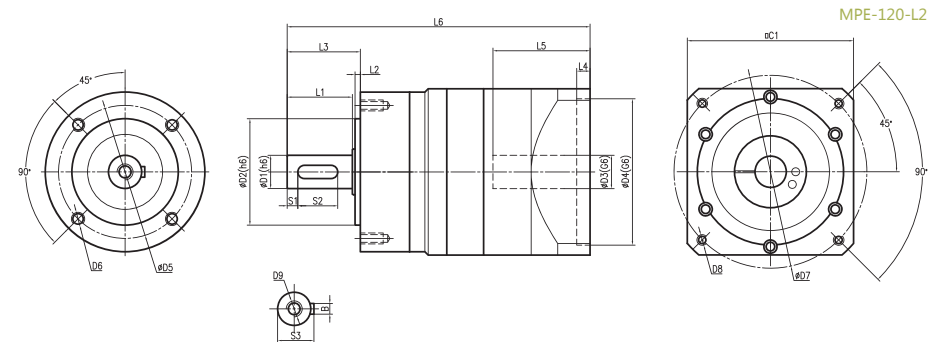

Flange	D1	D2	D3*	D4*	D5	D6	D7*	D8*	D9	L1	L2	L3	L4*	L5*	L6*	C1*	S1	S2	S3	B
Type I	Φ25	Φ80	Φ19	Φ70	Φ100	4-M10X20	Φ90	4-M5X12	M10X24	50	4	55	5	46.5	200.5	80	8	30	28	8
Type II	Φ25	Φ80	Φ22	Φ110	Φ100	4-M10X20	Φ145	4-M8X15	M10X24	50	4	55	11.5	63	226	125	8	30	28	8
Type III	Φ25	Φ80	Φ24	Φ110	Φ100	4-M10X20	Φ145	4-M8X15	M10X24	50	4	55	11.5	63	226	125	8	30	28	8

\*Dimensions based on servo-motor, please contact us for custom made order.  
注有 \* 尺寸：代表可根据客户需求定制产品，如有需要，请联系我们！

\*Dimensions based on servo-motor, please contact us for custom made order.  
注有 \* 尺寸：代表可根据客户需求定制产品，如有需要，请联系我们！

MPE-040																	
Symb.	i	T <sub>2N</sub>	T <sub>2Not</sub>	n <sub>1N</sub>	n <sub>1Max</sub>	j <sub>i</sub>	C <sub>2t</sub>	F <sub>Z2RMax</sub>	F <sub>Z2AMax</sub>	J <sub>1</sub>	η	L <sub>n</sub>	T	Lub	PC	MP	dB
Unit		N <sub>m</sub>	N <sub>m</sub>	rpm	rpm	arcmin	NmV/arcmin	N	N	kgcm <sup>2</sup>	%	h	°C				
I STAGE	3	8								0.031	≥95			Life Lubrication 终身润滑	IP65	Any 任何方向	≤64
	4	10							0.022								
	5	10							0.019								
	6	10							0.019								
	7	10							0.017								
	8	10							0.017								
	9	8							0.017								
	10	8							0.016								
	15	8							0.015								
	20	10							0.007								
II STAGE	25	10							0.007	≥90							
	50	10							0.015								
	80	10							0.007								
	100	8							0.007								
	15	8							0.015								
	20	10							0.007								

MPE-090																	
Symb.	i	T <sub>2N</sub>	T <sub>2Not</sub>	n <sub>1N</sub>	n <sub>1Max</sub>	j <sub>i</sub>	C <sub>2t</sub>	F <sub>Z2RMax</sub>	F <sub>Z2AMax</sub>	J <sub>1</sub>	η	L <sub>n</sub>	T	Lub	PC	MP	dB
Unit		N <sub>m</sub>	N <sub>m</sub>	rpm	rpm	arcmin	NmV/arcmin	N	N	kgcm <sup>2</sup>	%	h	°C				
I STAGE	3	55								0.77	≥95			Life Lubrication 终身润滑	IP65	Any 任何方向	≤72
	4	60							0.52								
	5	75							0.45								
	6	75							0.45								
	7	75							0.39								
	8	75							0.39								
	9	55							0.45								
	10	55							0.74								
	15	55							0.71								
	20	75							0.44								
II STAGE	25	75							0.44	≥90							
	50	75							0.51								
	80	75							0.50								
	100	55							0.44								
	15	55							0.71								
	20	75							0.44								

MPE-060																	
Symb.	i	T <sub>2N</sub>	T <sub>2Not</sub>	n <sub>1N</sub>	n <sub>1Max</sub>	j <sub>i</sub>	C <sub>2t</sub>	F <sub>Z2RMax</sub>	F <sub>Z2AMax</sub>	J <sub>1</sub>	η	L <sub>n</sub>	T	Lub	PC	MP	dB
Unit		N <sub>m</sub>	N <sub>m</sub>	rpm	rpm	arcmin	NmV/arcmin	N	N	kgcm <sup>2</sup>	%	h	°C				
I STAGE	3	20								0.135	≥95			Life Lubrication 终身润滑	IP65	Any 任何方向	≤68
	4	30							0.093								
	5	35							0.078								
	6	35							0.078								
	7	35							0.075								
	8	35							0.075								
	9	20							0.065								
	10	20							0.063								
	15	20							0.065								
	20	30							0.075								
II STAGE	25	35							0.075	≥90							
	50	35							0.076								
	80	35							0.075								
	100	20							0.075								
	15	20							0.065								
	20	30							0.075								

MPE-120																	
Symb.	i	T <sub>2N</sub>	T <sub>2Not</sub>	n <sub>1N</sub>	n <sub>1Max</sub>	j <sub>i</sub>	C <sub>2t</sub>	F <sub>Z2RMax</sub>	F <sub>Z2AMax</sub>	J <sub>1</sub>	η	L <sub>n</sub>	T	Lub	PC	MP	dB
Unit		N <sub>m</sub>	N <sub>m</sub>	rpm	rpm	arcmin	NmV/arcmin	N	N	kgcm <sup>2</sup>	%	h	°C				
I STAGE	3	140								2.63	≥95			Life Lubrication 终身润滑	IP65	Any 任何方向	≤75
	4	180							1.79								
	5	180							1.53								
	6	180							1.53								
	7	180							1.32								
	8	180							1.32								
	9	140							1.32								
	10	140							1.53								
	15	140							1.75								
	20	180							1.50								
II STAGE	25	180							1.49	≥90							
	50	180							1.53								
	80	180							1.50								
	100	140							1.49								
	15	140							1.75								
	20	180							1.50								

MPE

MPE

**Efficiency**

The efficiency of planetary reducers varies with several parameters such as ratio, input speed, temperature, lubrication conditions, etc.

The efficiency was measured under the following working conditions:

Input speed ( rpm )	3000
Operating temperature ( °C )	25
Lubricant	Standard

**效率特性**

减速机的效率一般因减速比、输入转速、负载转速、温度、润滑条件而异。在下列测定条件下，各系列的效率如下所示。此外，图表的数值均为平均值。

输入转速 (rpm)	3000
环境温度 (°C)	25
润滑剂	标准润滑剂

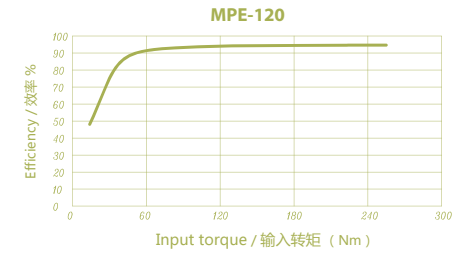
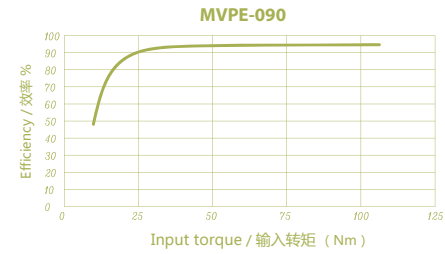
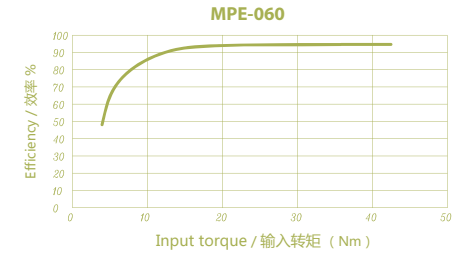
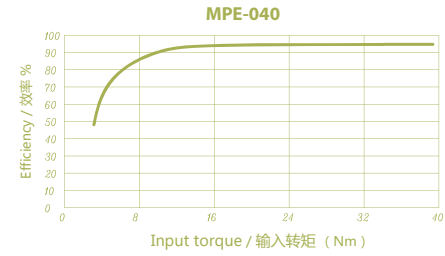



此经济款专用于较低技术要求应用。  
Economic series dedicated to low challenging applications.

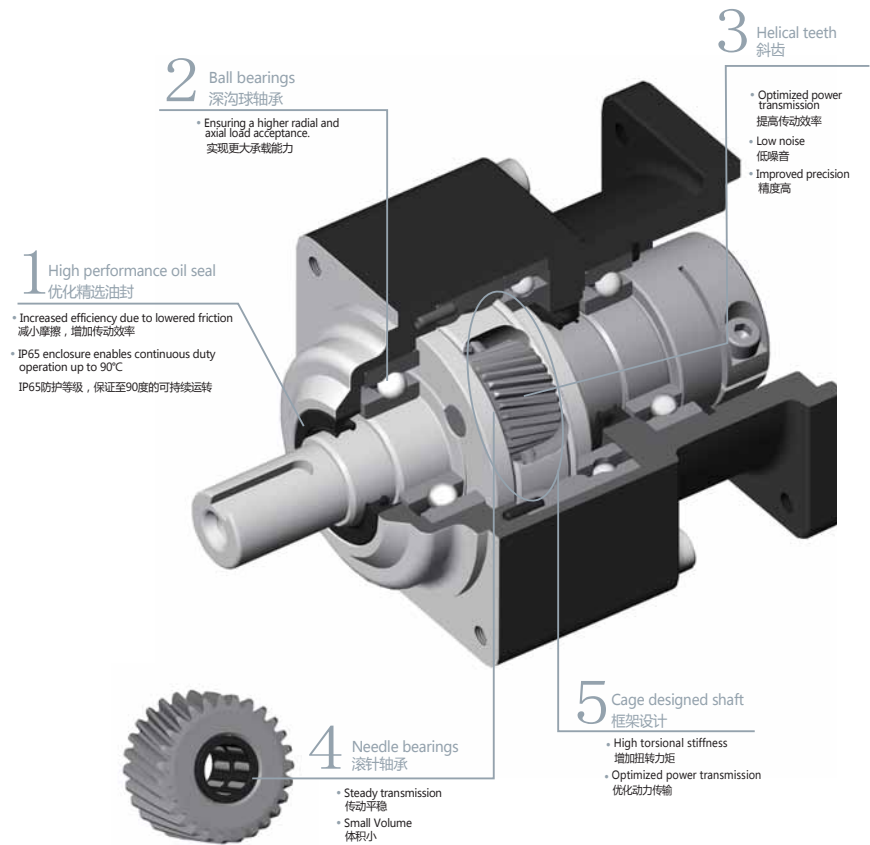

**造型数据:**  
**Selection data:**

扭矩 ( Nm )	5-330
速比	3-100
背隙 ( arcmin )	≤12
最大工作温度 ( °C )	90
噪音 ( dB )	60-80

Nominal output torque ( Nm )	5-330
Reduction ratio	3-100
Backlash ( arcmin )	≤12
Max.working temperature ( °C )	90
Noise ( dB )	60-80