

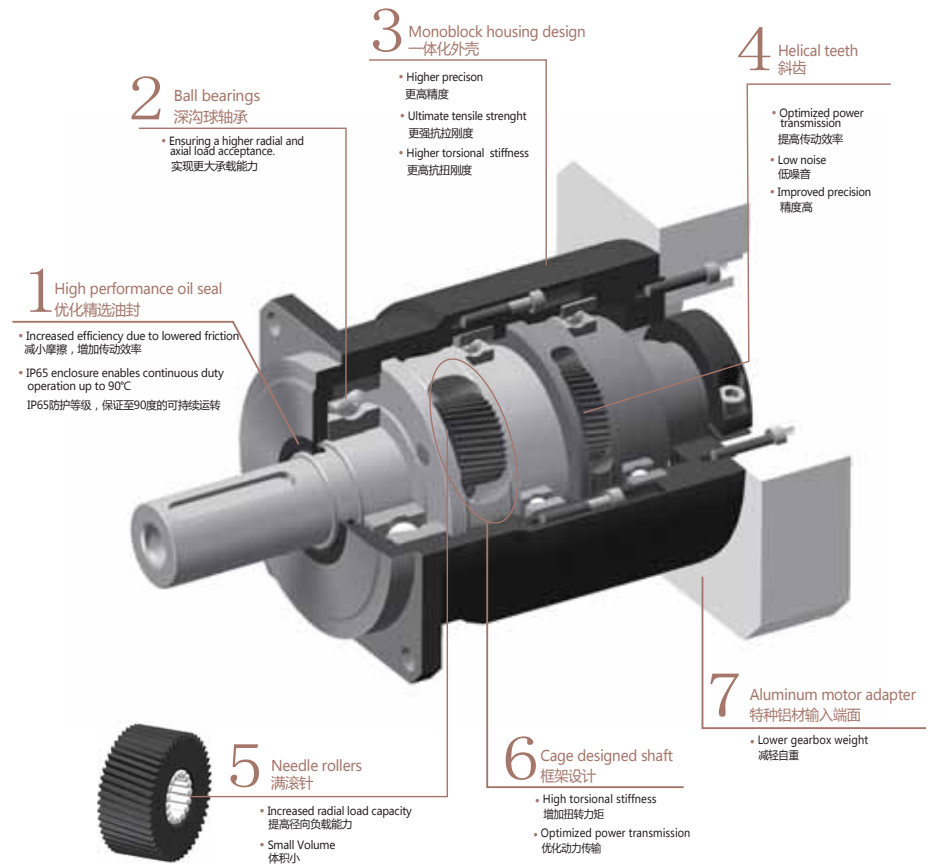

专门为频繁反复和紧急加速而设计，MVB系列可提供高精度、高刚性和高扭矩。

Powerful, robust and precise, this planetary gearbox is designed to work under heavy operating duty.



**造型数据:**

**Selection data:**

扭矩 ( Nm )	14-2300
速比	3-100
背隙 ( arcmin )	3-5
最大工作温度 ( °C )	90
噪音 ( dB )	63-77

Nominal output torque ( Nm )	14-2300
Reduction ratio	3-100
Backlash ( arcmin )	3-5
Max.working temperature ( °C )	90
Noise ( dB )	63-77

MVB-040-L1

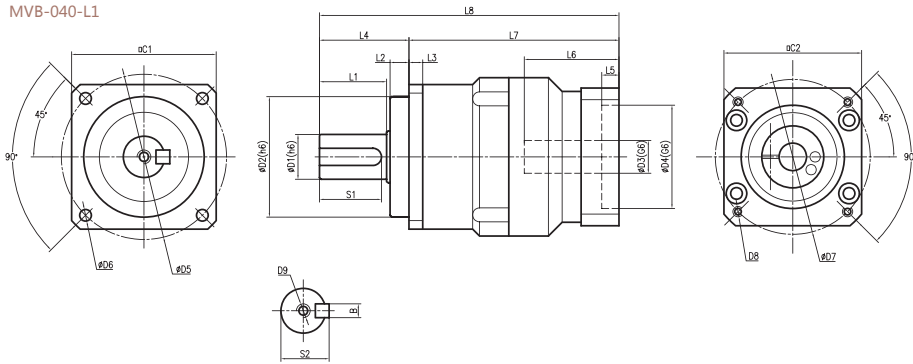

Flange	D1	D2	D3*	D4*	D5	D6	D7*	D8*	D9	L1	L2	L3	L4	L5*	L6*	L7*	L8*	C1	C2*	S1	S2	B
Type I	$\Phi 13$	$\Phi 35$	$\Phi 8$	$\Phi 30$	$\Phi 50$	4- $\Phi 3.4$	$\Phi 46$	4-M4X10	M4X10	18	5	4	24.5	5	32	66	90.5	42	40	16	15	5
Type II	$\Phi 13$	$\Phi 35$	$\Phi 11$	$\Phi 50$	$\Phi 50$	4- $\Phi 3.4$	$\Phi 70$	4-M4X10	M4X10	18	5	4	24.5	5	32	66	90.5	42	60	16	15	5

MVB-060-L1

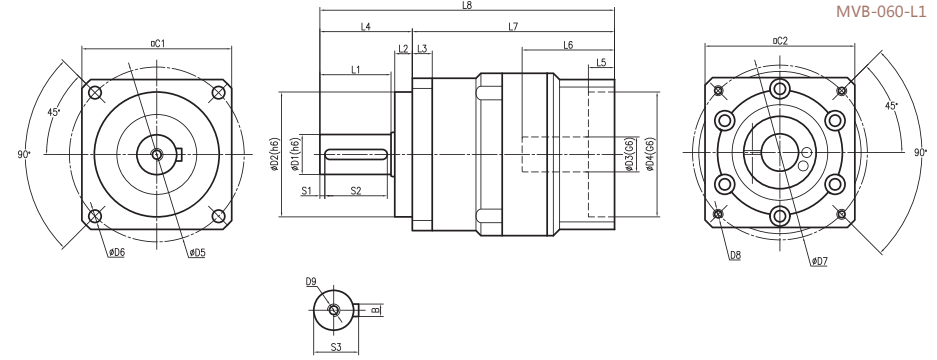

Flange	D1	D2	D3*	D4*	D5	D6	D7*	D8*	D9	L1	L2	L3	L4	L5*	L6*	L7*	L8*	C1	C2*	S1	S2	S3	B
Type I	$\Phi 16$	$\Phi 50$	$\Phi 11$	$\Phi 50$	$\Phi 70$	4- $\Phi 5.5$	$\Phi 70$	4-M5X12	M5X12	28.5	7	8	37	11	37	81	118	60	60	2	25	18	5
Type II	$\Phi 16$	$\Phi 50$	$\Phi 14$	$\Phi 50$	$\Phi 70$	4- $\Phi 5.5$	$\Phi 70$	4-M5X12	M5X12	28.5	7	8	37	11	37	81	118	60	60	2	25	18	5
Type III	$\Phi 16$	$\Phi 50$	$\Phi 19$	$\Phi 70$	$\Phi 70$	4- $\Phi 5.5$	$\Phi 90$	4-M5X12	M5X12	28.5	7	8	37	10.5	37	86	123	60	80	2	25	18	5

MVB-040-L2

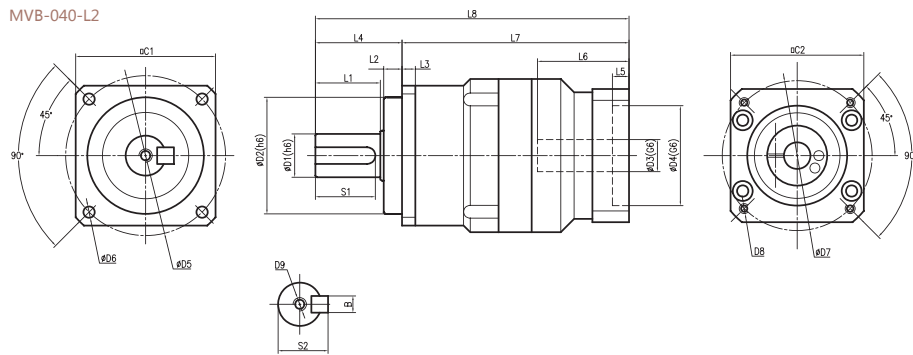

Flange	D1	D2	D3*	D4*	D5	D6	D7*	D8*	D9	L1	L2	L3	L4	L5*	L6*	L7*	L8*	C1	C2*	S1	S2	B
Type I	$\Phi 13$	$\Phi 35$	$\Phi 8$	$\Phi 30$	$\Phi 50$	4- $\Phi 3.4$	$\Phi 45$	4-M3X8	M4X10	18	5	4	24.5	5	32	81.5	106	42	40	16	15	5
Type II	$\Phi 13$	$\Phi 35$	$\Phi 8$	$\Phi 30$	$\Phi 50$	4- $\Phi 3.4$	$\Phi 46$	4-M4X10	M4X10	18	5	4	24.5	5	32	81.5	106	42	40	16	15	5

MVB-060-L2

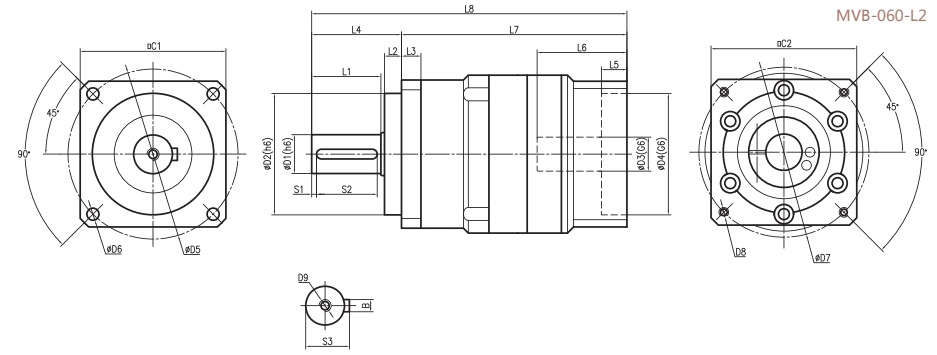

Flange	D1	D2	D3*	D4*	D5	D6	D7*	D8*	D9	L1	L2	L3	L4	L5*	L6*	L7*	L8*	C1	C2*	S1	S2	S3	B
Type I	$\Phi 16$	$\Phi 50$	$\Phi 11$	$\Phi 50$	$\Phi 70$	4- $\Phi 5.5$	$\Phi 70$	4-M5X12	M5X12	28.5	7	8	37	11	37	101	138	60	60	2	25	18	5
Type II	$\Phi 16$	$\Phi 50$	$\Phi 14$	$\Phi 50$	$\Phi 70$	4- $\Phi 5.5$	$\Phi 70$	4-M5X12	M5X12	28.5	7	8	37	11	37	101	138	60	60	2	25	18	5

\*Dimensions based on servo-motor, please contact us for custom made order.  
注有 \* 尺寸：代表可根据客户需求定制产品，如有需要，请联系我们！

\*Dimensions based on servo-motor, please contact us for custom made order.  
注有 \* 尺寸：代表可根据客户需求定制产品，如有需要，请联系我们！

MVB-090-L1

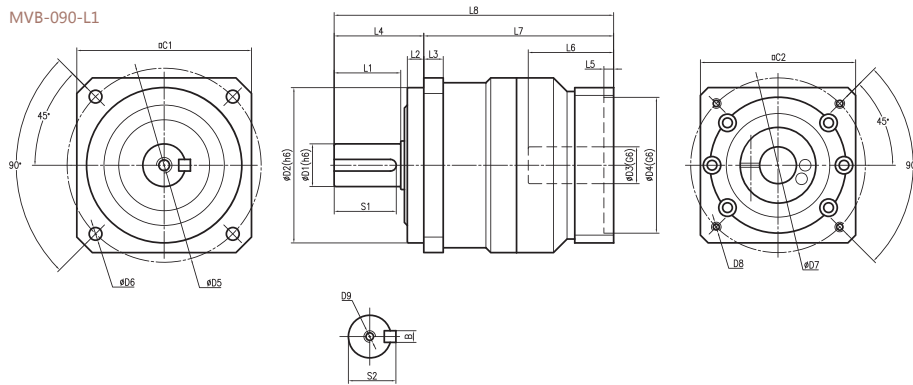

Flange	D1	D2	D3*	D4*	D5	D6	D7*	D8*	D9	L1	L2	L3	L4	L5*	L6*	L7*	L8*	C1	C2*	S1	S2	B
Type I	Φ22	Φ80	Φ19	Φ70	Φ100	4-Φ6.6	Φ90	4-M6X12	M8X20	35.5	10	8	48	5	44	96	144	90	80	32	24.5	6
Type II	Φ22	Φ80	Φ22	Φ110	Φ100	4-Φ6.6	Φ145	4-M8X16	M8X20	35.5	10	8	48	10	59	111	159	90	130	32	24.5	6
Type III	Φ22	Φ80	Φ24	Φ110	Φ100	4-Φ6.6	Φ145	4-M8X16	M8X20	35.5	10	8	48	10	59	111	159	90	130	32	24.5	6

MVB-120-L1

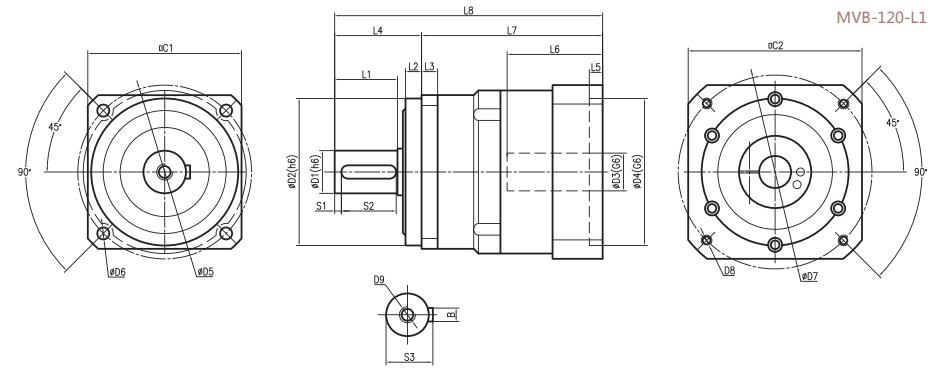

Flange	D1	D2	D3*	D4*	D5	D6	D7*	D8*	D9	L1	L2	L3	L4	L5*	L6*	L7*	L8*	C1	C2*	S1	S2	S3	B
Type I	Φ32	Φ110	Φ22	Φ110	Φ130	4-Φ9	Φ145	4-M8X18	M12X28	49.5	12	12	65	10	71.5	135.5	200.5	115	130	5	40	35	10
Type II	Φ32	Φ110	Φ24	Φ110	Φ130	4-Φ9	Φ145	4-M8X18	M12X28	49.5	12	12	65	10	71.5	135.5	200.5	115	130	5	40	35	10
Type III	Φ32	Φ110	Φ28	Φ110	Φ130	4-Φ9	Φ145	4-M8X18	M12X28	49.5	12	12	65	10	71.5	135.5	200.5	115	130	5	40	35	10
Type IV	Φ32	Φ110	Φ35	Φ114.3	Φ130	4-Φ9	Φ200	4-M12X25	M12X28	49.5	12	12	65	10	81.5	145.5	210.5	115	180	5	40	35	10

MVB-090-L2

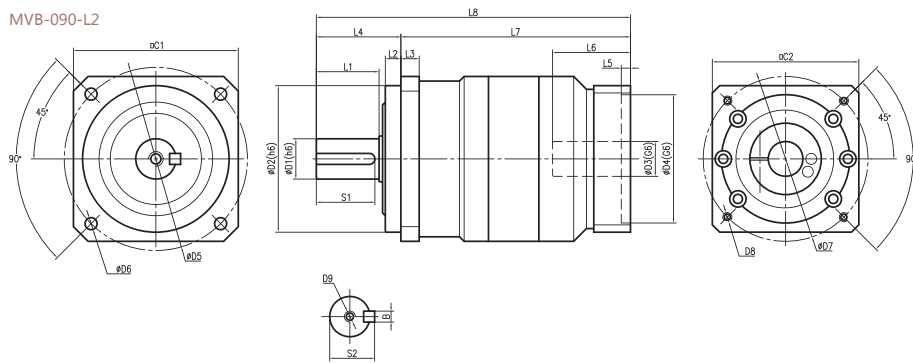

Flange	D1	D2	D3*	D4*	D5	D6	D7*	D8*	D9	L1	L2	L3	L4	L5*	L6*	L7*	L8*	C1	C2*	S1	S2	B
Type I	Φ22	Φ80	Φ14	Φ50	Φ100	4-Φ6.6	Φ70	4-M4X10	M8X 20	35.5	10	8	48	10.5	37	111.5	159.5	90	60	32	24.5	6
Type II	Φ22	Φ80	Φ19	Φ70	Φ100	4-Φ6.6	Φ90	4-M8X16	M8X 20	35.5	10	8	48	11	49.5	130.5	178.5	90	80	32	24.5	6
Type III	Φ22	Φ80	Φ22	Φ110	Φ100	4-Φ6.6	Φ145	4-M8X16	M8X 20	35.5	10	8	48	10	57.5	138.5	186.5	90	130	32	24.5	6

MVB-120-L2

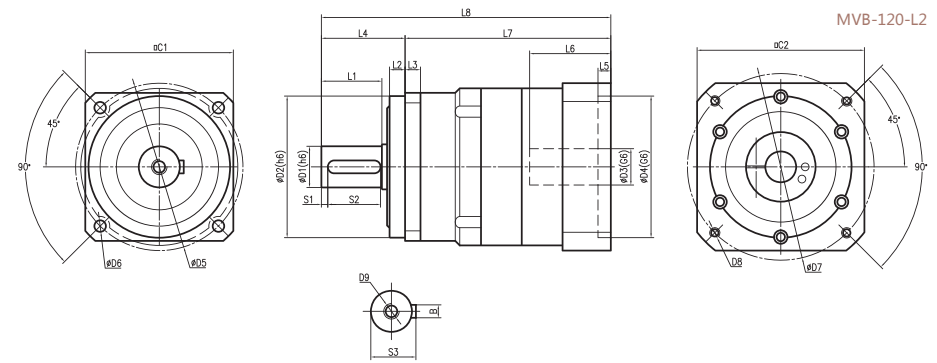

Flange	D1	D2	D3*	D4*	D5	D6	D7*	D8*	D9	L1	L2	L3	L4	L5*	L6*	L7*	L8*	C1	C2*	S1	S2	S3	B
Type I	Φ32	Φ110	Φ19	Φ70	Φ130	4-Φ9	Φ90	4-M5X10	M12X28	49.5	12	12	65	11	49.5	138.5	203.5	115	80	5	40	35	10
Type II	Φ32	Φ110	Φ22	Φ110	Φ130	4-Φ9	Φ145	4-M8X18	M12X28	49.5	12	12	65	10	71.5	169	234	115	130	5	40	35	10
Type III	Φ32	Φ110	Φ24	Φ110	Φ130	4-Φ9	Φ145	4-M8X18	M12X28	49.5	12	12	65	10	71.5	169	234	115	130	5	40	35	10

\*Dimensions based on servo-motor, please contact us for custom made order.  
注有 \* 尺寸：代表可根据客户需求定制产品，如有需要，请联系我们！

\*Dimensions based on servo-motor, please contact us for custom made order.  
注有 \* 尺寸：代表可根据客户需求定制产品，如有需要，请联系我们！

MVB-140-L1

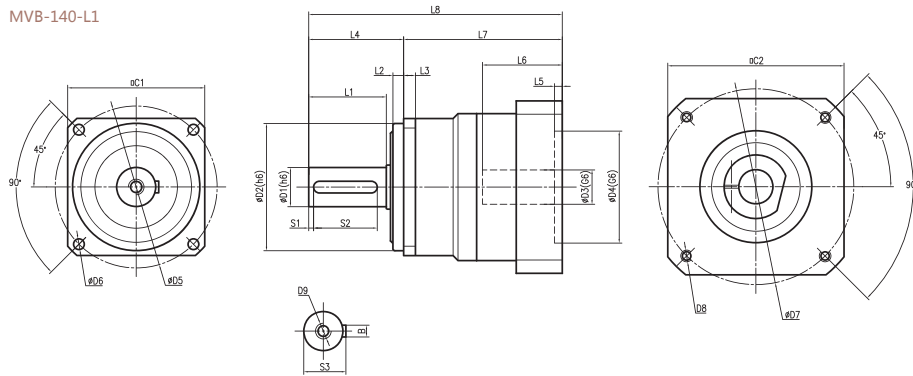

Flange	D1	D2	D3*	D4*	D5	D6	D7*	D8*	D9	L1	L2	L3	L4	L5*	L6*	L7*	L8*	C1	C2*	S1	S2	S3	B
Type I	Φ40	Φ130	Φ24	Φ110	Φ165	4-Φ11	Φ145	4-M8X18	M16X36	82	12	12	97	6	69	149.5	246.5	140	130	5	65	43	12
Type II	Φ40	Φ130	Φ28	Φ110	Φ165	4-Φ11	Φ145	4-M8X18	M16X36	82	12	12	97	6	69	149.5	246.5	140	130	5	65	43	12
Type III	Φ40	Φ130	Φ35	Φ110	Φ165	4-Φ11	Φ145	4-M8X18	M16X36	82	12	12	97	8	81.5	162	259	140	180	5	65	43	12
Type IV	Φ40	Φ130	Φ38	Φ114.3	Φ165	4-Φ11	Φ200	4-M12X25	M16X36	82	12	12	97	8	81.5	162	259	140	180	5	65	43	12

MVB-180-L1

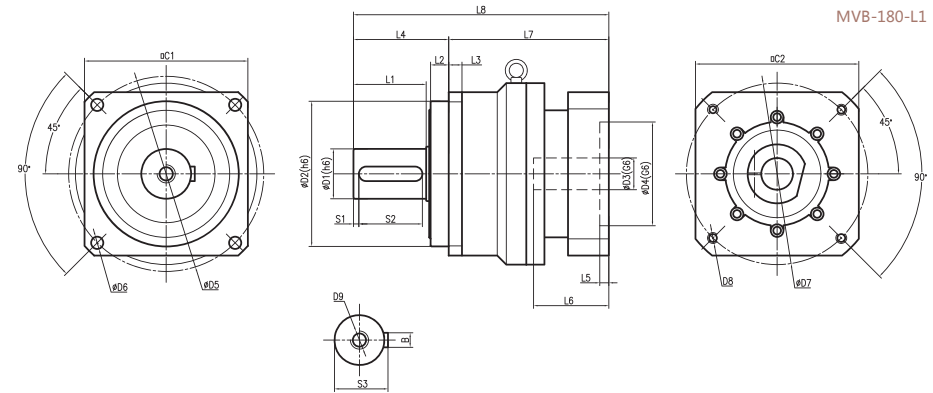

Flange	D1	D2	D3*	D4*	D5	D6	D7*	D8*	D9	L1	L2	L3	L4	L5*	L6*	L7*	L8*	C1	C2*	S1	S2	S3	B
Type I	Φ55	Φ160	Φ38	Φ114.3	Φ215	4-Φ13.5	Φ200	4-M12X25	M20X42	82	20	15	105	10	83	176.5	281.5	180	180	6	70	59	16
Type II	Φ55	Φ160	Φ42	Φ114.3	Φ215	4-Φ13.5	Φ200	4-M12X25	M20X42	82	20	15	105	12	85	178.5	283.5	180	180	6	70	59	16
Type III	Φ55	Φ160	Φ48	Φ200	Φ215	4-Φ13.5	Φ235	4-M12X25	M20X42	82	20	15	105	12	85	178.5	283.5	180	220	6	70	59	16

MVB-140-L2

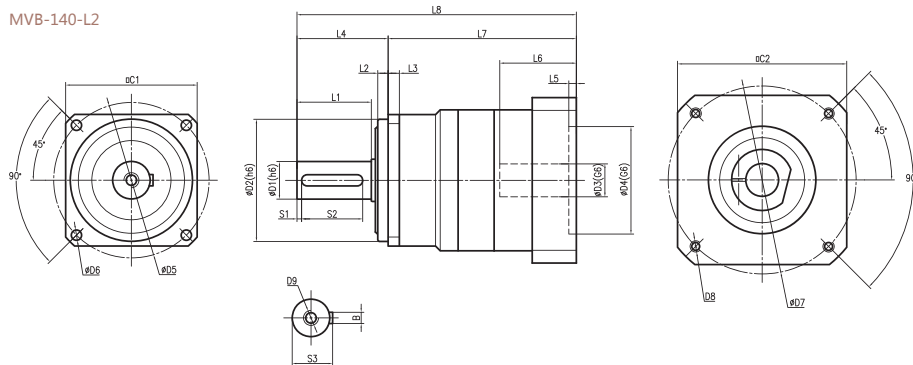

Flange	D1	D2	D3*	D4*	D5	D6	D7*	D8*	D9	L1	L2	L3	L4	L5*	L6*	L7*	L8*	C1	C2*	S1	S2	S3	B
Type I	Φ40	Φ130	Φ24	Φ110	Φ165	4-Φ11	Φ145	4-M8X18	M16X36	82	12	12	97	6	69	203	300	140	130	5	65	43	12
Type II	Φ40	Φ130	Φ28	Φ110	Φ165	4-Φ11	Φ145	4-M8X18	M16X36	82	12	12	97	6	69	203	300	140	130	5	65	43	12
Type III	Φ40	Φ130	Φ35	Φ110	Φ165	4-Φ11	Φ145	4-M12X25	M16X36	82	12	12	97	8	81.5	215.5	312.5	140	180	5	65	43	12
Type IV	Φ40	Φ130	Φ38	Φ114.3	Φ165	4-Φ11	Φ200	4-M12X25	M16X36	82	12	12	97	8	81.5	215.5	312.5	140	180	5	65	43	12

MVB-180-L2

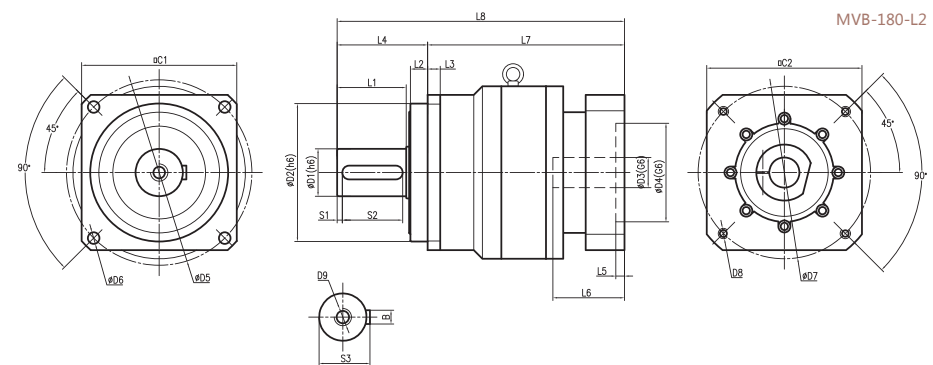

Flange	D1	D2	D3*	D4*	D5	D6	D7*	D8*	D9	L1	L2	L3	L4	L5*	L6*	L7*	L8*	C1	C2*	S1	S2	S3	B
Type I	Φ55	Φ160	Φ24	Φ110	Φ215	4-Φ13.5	Φ145	4-M8X18	M20X42	82	20	15	105	10	83	228.5	333.5	180	130	6	70	59	16
Type II	Φ55	Φ160	Φ38	Φ114.3	Φ215	4-Φ13.5	Φ200	4-M12X25	M20X42	82	20	15	105	10	83	228.5	333.5	180	180	6	70	59	16
Type III	Φ55	Φ160	Φ48	Φ200	Φ215	4-Φ13.5	Φ235	4-M12X25	M20X42	82	20	15	105	12	85	228.5	333.5	180	220	6	70	59	16

\*Dimensions based on servo-motor, please contact us for custom made order.  
注有 \* 尺寸：代表可根据客户需求定制产品，如有需要，请联系我们！

\*Dimensions based on servo-motor, please contact us for custom made order.  
注有 \* 尺寸：代表可根据客户需求定制产品，如有需要，请联系我们！

MVB-220-L1

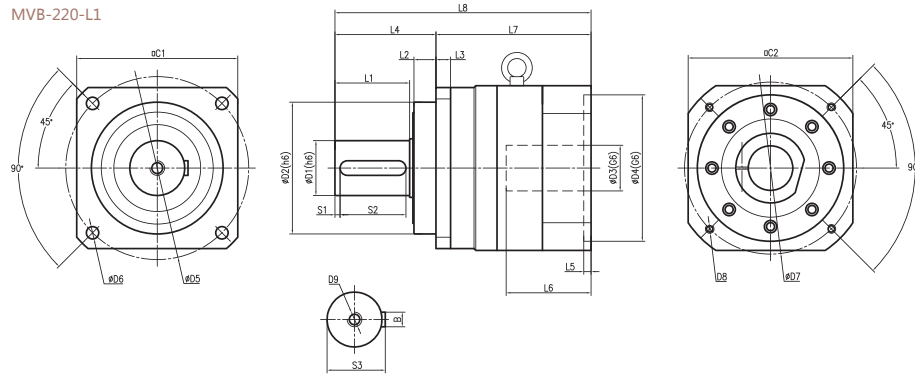

Flange	D1	D2	D3*	D4*	D5	D6	D7*	D8*	D9	L1	L2	L3	L4	L5*	L6*	L7*	L8*	C1	C2*	S1	S2	S3	B
Type I	Φ75	Φ180	Φ48	Φ200	Φ250	4-Φ17	Φ235	4-M12X25	M20X42	105	30	20	138	10	116	212	350	220	225	7	90	79.5	20
Type II	Φ75	Φ180	Φ55	Φ200	Φ250	4-Φ17	Φ235	4-M12X25	M20X42	105	30	20	138	10	116	212	350	220	225	7	90	79.5	20

MVB-220-L2

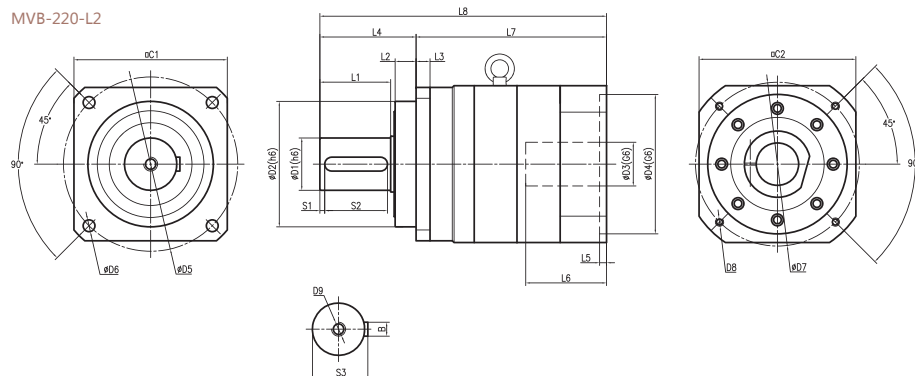

Flange	D1	D2	D3*	D4*	D5	D6	D7*	D8*	D9	L1	L2	L3	L4	L5*	L6*	L7*	L8*	C1	C2*	S1	S2	S3	B
Type I	Φ75	Φ180	Φ48	Φ200	Φ250	4-Φ17	Φ235	4-M12X25	M20X42	105	30	20	138	10	116	212	409.5	220	225	7	90	79.5	20
Type II	Φ75	Φ180	Φ55	Φ200	Φ250	4-Φ17	Φ235	4-M12X25	M20X42	105	30	20	138	10	116	212	409.5	220	225	7	90	79.5	20

\*Dimensions based on servo-motor, please contact us for custom made order.  
注有 \* 尺寸：代表可根据客户需求定制产品，如有需要，请联系我们！

MVB-040																		
Symb.	i	T <sub>2N</sub>	T <sub>2Not</sub>	n <sub>1N</sub>	n <sub>1Max</sub>	j <sub>t</sub>	C <sub>2t</sub>	F <sub>Z2RMax</sub>	F <sub>Z2AMax</sub>	J <sub>1</sub>	η	L <sub>h</sub>	T	Lub	PC	MP	dB	
Unit		Nm	Nm	rpm	rpm	arcmin	Nm/arcmin	N	N	kgcm <sup>2</sup>	%	h	°C					
I STAGE	3	14					3											
	4	14					3											
	5	20					3											
	6	20					3											
	7	20				≤3	2.2				≥95							
	8	20					3											
	9	14					3											
	10	14					2.2	700	610	0.03		>20000	-15~45	Life Lubrication 终身润滑	IP65	Any 任何方向	≤63	
	15	14	2×T <sub>2N</sub>	4000	8000		3											
	20	14					3											
II STAGE	35	20					3											
	40	20				≤5	3				≥90							
	50	20					3											
	80	20					3											
	100	14					2.2											

MVB-060																		
Symb.	i	T <sub>2N</sub>	T <sub>2Not</sub>	n <sub>1N</sub>	n <sub>1Max</sub>	j <sub>t</sub>	C <sub>2t</sub>	F <sub>Z2RMax</sub>	F <sub>Z2AMax</sub>	J <sub>1</sub>	η	L <sub>h</sub>	T	Lub	PC	MP	dB	
Unit		Nm	Nm	rpm	rpm	arcmin	Nm/arcmin	N	N	kgcm <sup>2</sup>	%	h	°C					
I STAGE	3	34					7											
	4	50					7											
	5	50					7											
	6	50					7											
	7	50				≤3	7				≥95							
	8	50					7											
	9	35					7											
	10	35					7											
	15	35	2×T <sub>2N</sub>	3000	6000		7	1200	1050				>20000	-15~45	Life Lubrication 终身润滑	IP65	Any 任何方向	≤65
	20	50					7											
II STAGE	35	50					7											
	40	50				≤5	7				≥90							
	50	50					7											
	80	50					7											
	100	35					7											

Performance table

Performance table

MVB-090																															
Symb.	i	T <sub>2N</sub>	T <sub>2Not</sub>	n <sub>1N</sub>	n <sub>1Max</sub>	j <sub>t</sub>	C <sub>2t</sub>	F <sub>ZRMMax</sub>	F <sub>ZAMMax</sub>	J <sub>1</sub>	η	L <sub>h</sub>	T	Lub	PC	MP	dB														
Unit		N <sub>m</sub>	N <sub>m</sub>	rpm	rpm	arcmin	NmV/arcmin	N	N	kgcm <sup>2</sup>	%	h	°C																		
I STAGE	3	80	2×T <sub>2N</sub>	3000	6000	≤3	14	2450	2200	0.61	≥95	> 20000	-15~45	Life Lubrication 终身润滑	IP65	Any 任何方向	≤67														
	4	120					14			0.48																					
	5	125					14			0.47																					
	6	125					14			0.47																					
	7	125					14			0.45																					
	8	125					14			0.45																					
	9	80					14			0.42																					
	10	80					14			0.40																					
	II STAGE	15					80			2×T <sub>2N</sub>								3000	6000	≤5	14	2450	2200	0.45	≥90	> 20000	-15~45	Life Lubrication 终身润滑	IP65	Any 任何方向	≤67
		20					125														14			0.45							
35		125	14	0.45																											
40		125	14	0.45																											
50		125	14	0.40																											
80		125	14	0.40																											
100		80	14	0.40																											

MVB-140																															
Symb.	i	T <sub>2N</sub>	T <sub>2Not</sub>	n <sub>1N</sub>	n <sub>1Max</sub>	j <sub>t</sub>	C <sub>2t</sub>	F <sub>ZRMMax</sub>	F <sub>ZAMMax</sub>	J <sub>1</sub>	η	L <sub>h</sub>	T	Lub	PC	MP	dB														
Unit		N <sub>m</sub>	N <sub>m</sub>	rpm	rpm	arcmin	NmV/arcmin	N	N	kgcm <sup>2</sup>	%	h	°C																		
I STAGE	3	460	2×T <sub>2N</sub>	3000	6000	≤3	50	9000	8300	9.21	≥95	> 20000	-15~45	Life Lubrication 终身润滑	IP65	Any 任何方向	≤72														
	4	650					50			7.54																					
	5	700					50			7.42																					
	6	700					50			7.42																					
	7	700					50			7.14																					
	8	700					50			7.14																					
	9	500					50			7.08																					
	10	460					50			7.03																					
	II STAGE	15					460			2×T <sub>2N</sub>								3000	6000	≤5	50	9000	8300	2.63	≥90	> 20000	-15~45	Life Lubrication 终身润滑	IP65	Any 任何方向	≤72
		20					650														50			2.63							
35		700	50	2.43																											
40		650	50	2.43																											
50		700	50	2.39																											
80		700	50	2.39																											
100		460	50	2.39																											

MVB-120																															
Symb.	i	T <sub>2N</sub>	T <sub>2Not</sub>	n <sub>1N</sub>	n <sub>1Max</sub>	j <sub>t</sub>	C <sub>2t</sub>	F <sub>ZRMMax</sub>	F <sub>ZAMMax</sub>	J <sub>1</sub>	η	L <sub>h</sub>	T	Lub	PC	MP	dB														
Unit		N <sub>m</sub>	N <sub>m</sub>	rpm	rpm	arcmin	NmV/arcmin	N	N	kgcm <sup>2</sup>	%	h	°C																		
I STAGE	3	220	2×T <sub>2N</sub>	3000	6000	≤3	25	4400	4000	3.25	≥95	> 20000	-15~45	Life Lubrication 终身润滑	IP65	Any 任何方向	≤70														
	4	300					25			2.74																					
	5	350					25			2.71																					
	6	350					25			2.71																					
	7	330					25			2.62																					
	8	360					25			2.60																					
	9	240					25			2.59																					
	10	220					25			2.57																					
	II STAGE	15					220			2×T <sub>2N</sub>								3000	6000	≤5	25	4400	4000	0.45	≥90	> 20000	-15~45	Life Lubrication 终身润滑	IP65	Any 任何方向	≤70
		20					300														25			0.45							
35		350	25	0.45																											
40		300	25	0.45																											
50		330	25	0.40																											
80		360	25	0.40																											
100		220	25	0.40																											

MVB-180																															
Symb.	i	T <sub>2N</sub>	T <sub>2Not</sub>	n <sub>1N</sub>	n <sub>1Max</sub>	j <sub>t</sub>	C <sub>2t</sub>	F <sub>ZRMMax</sub>	F <sub>ZAMMax</sub>	J <sub>1</sub>	η	L <sub>h</sub>	T	Lub	PC	MP	dB														
Unit		N <sub>m</sub>	N <sub>m</sub>	rpm	rpm	arcmin	NmV/arcmin	N	N	kgcm <sup>2</sup>	%	h	°C																		
I STAGE	3	980	2×T <sub>2N</sub>	2000	4000	≤3	145	14500	13500	28.98	≥95	> 20000	-15~45	Life Lubrication 终身润滑	IP65	Any 任何方向	≤75														
	4	1350					145			23.67																					
	5	1400					145			23.29																					
	6	1400					145			22.29																					
	7	1400					145			22.48																					
	8	1400					145			22.48																					
	9	980					145			22.40																					
	10	980					145			22.51																					
	II STAGE	15					980			2×T <sub>2N</sub>								2000	4000	≤5	145	14500	13500	7.3	≥90	> 20000	-15~45	Life Lubrication 终身润滑	IP65	Any 任何方向	≤75
		20					1350														145			7.3							
35		1400	145	7.1																											
40		1350	145	6.92																											
50		1400	145	6.92																											
80		1400	145	6.72																											
100		980	145	6.72																											

## Performance table

MVB-220																	
Symb.	i	T <sub>2N</sub>	T <sub>2Nst</sub>	n <sub>1N</sub>	n <sub>1Max</sub>	j <sub>t</sub>	C <sub>2t</sub>	F <sub>ZRMMax</sub>	F <sub>ZAMMax</sub>	J <sub>t</sub>	η	L <sub>h</sub>	T	Lub	PC	MP	dB
Unit		Nm	Nm	rpm	rpm	arcmin	Nm/arcmin	N	N	kgcm <sup>2</sup>	%	h	°C				
I STAGE	3	1600	2×T <sub>2N</sub>	1500	3000	≤3	225	20500	19000	69.61	≥95	>20000	-15~45	Life Lubrication 终身润滑	IP65	Any 任何方向	≤77
	4	2200					225			54.37							
	5	2300					225			53.27							
	6	2300					225			53.27							
	7	2300					225			50.97							
	8	2300					225			50.88							
	9	1800					225			50.73							
	10	1600					225			50.56							
	15	1600					225			22.79							
	II STAGE	20					2200			225							
35		2200	225	22.59													
40		2200	225	21.83													
50		2300	225	21.83													
80		2300	225	21.70													
100		1600	225	21.60													

### Efficiency

The efficiency of planetary reducers varies with several parameters such as ratio, input speed, temperature, lubrication conditions, etc.

The efficiency was measured under the following working conditions:

Input speed (rpm)	3000
Operating temperature (°C)	25
Lubricant	Standard

### 效率特性

减速机的效率一般因减速比、输入转速、负载转速、温度、润滑条件而异。在下列测定条件下，各系列的效率如下所示。此外，图表的数值均为平均值。

输入转速 (rpm)	3000
环境温度 (°C)	25
润滑剂	标准润滑剂

