

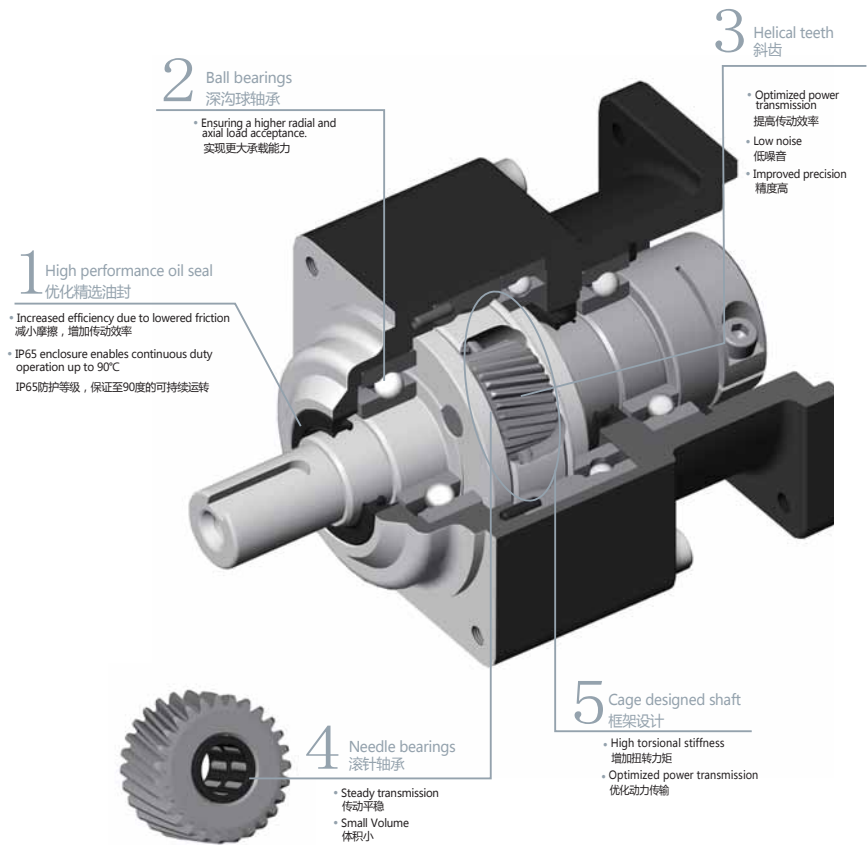

此经济款专用于较低技术要求应用。  
Economic series dedicated to low challenging applications.



**造型数据:**  
**Selection data:**

扭矩 ( Nm )	5-330
速比	3-100
背隙 ( arcmin )	≤12
最大工作温度 ( °C )	90
噪音 ( dB )	60-80

Nominal output torque ( Nm )	5-330
Reduction ratio	3-100
Backlash ( arcmin )	≤12
Max.working temperature ( °C )	90
Noise ( dB )	60-80

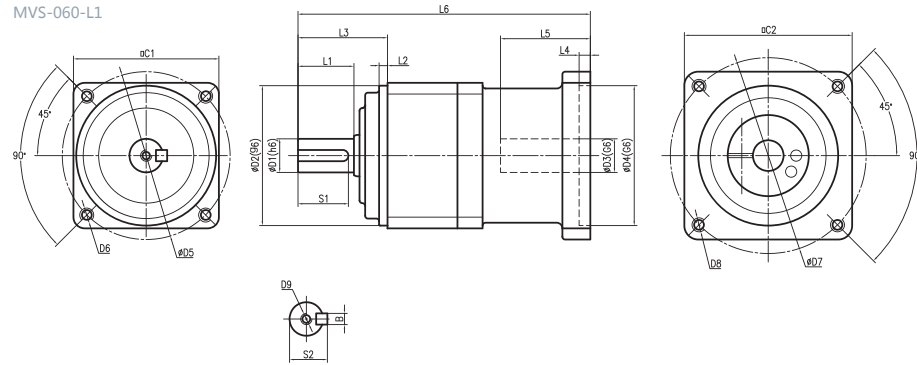

Flange	D1	D2	D3*	D4*	D5	D6	D7*	D8*	D9	L1	L2	L3	L4	L5*	L6*	C1	C2*	S1	S2	B
Type I	Φ12	Φ50	Φ8	Φ30	Φ60	4-M5	Φ45	4-M4	M4X10	20	3	32	4	40	104.5	52	40	18	13.5	4
Type II	Φ12	Φ50	Φ11	Φ50	Φ60	4-M5	Φ70	4-M4	M4X10	20	3	32	4	52	104.5	52	60	18	13.5	4
Type III	Φ12	Φ50	Φ14	Φ50	Φ60	4-M5	Φ70	4-M5	M4X10	20	3	32	4	52	104.5	52	60	18	13.5	4

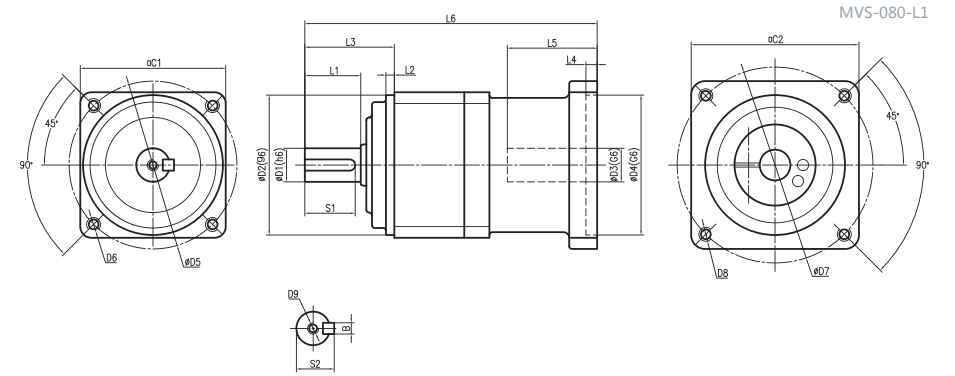

Flange	D1	D2	D3*	D4*	D5	D6	D7*	D8*	D9	L1	L2	L3	L4*	L5*	L6*	C1	C2*	S1	S2	B
Type I	Φ19	Φ70	Φ8	Φ50	Φ90	4-M6	Φ70	4-M4	M6X15	30	3	50	4	32	139.5	78	60	25	21.5	6
Type II	Φ19	Φ70	Φ14	Φ50	Φ90	4-M6	Φ70	4-M4	M6X15	30	3	50	4	32	139.5	78	60	25	21.5	6
Type III	Φ19	Φ70	Φ19	Φ70	Φ90	4-M6	Φ90	4-M5	M6X15	30	3	50	4	42	143.5	78	80	25	21.5	6

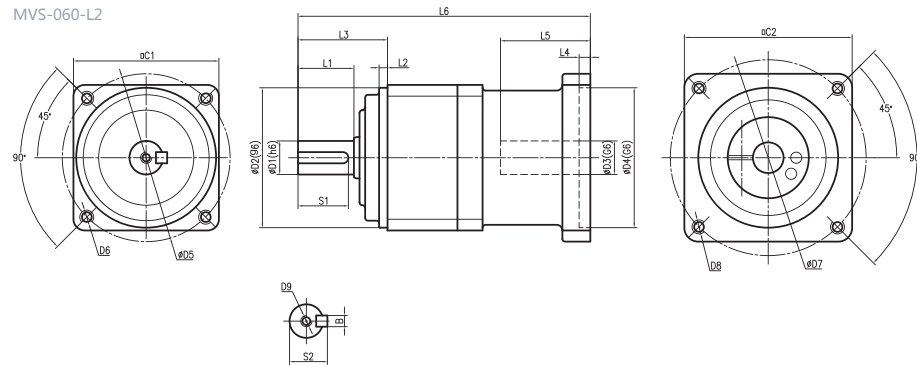

Flange	D1	D2	D3*	D4*	D5	D6	D7*	D8*	D9	L1	L2	L3	L4	L5*	L6*	C1	C2*	S1	S2	B
Type I	Φ12	Φ50	Φ8	Φ30	Φ60	4-M5	Φ45	4-M4	M4X10	20	3	32	4	40	114	52	40	18	13.5	4
Type II	Φ12	Φ50	Φ11	Φ50	Φ60	4-M5	Φ70	4-M4	M4X10	20	3	32	4	52	114	52	60	18	13.5	4
Type III	Φ12	Φ50	Φ14	Φ50	Φ60	4-M5	Φ70	4-M5	M4X10	20	3	32	4	52	114	52	60	18	13.5	4

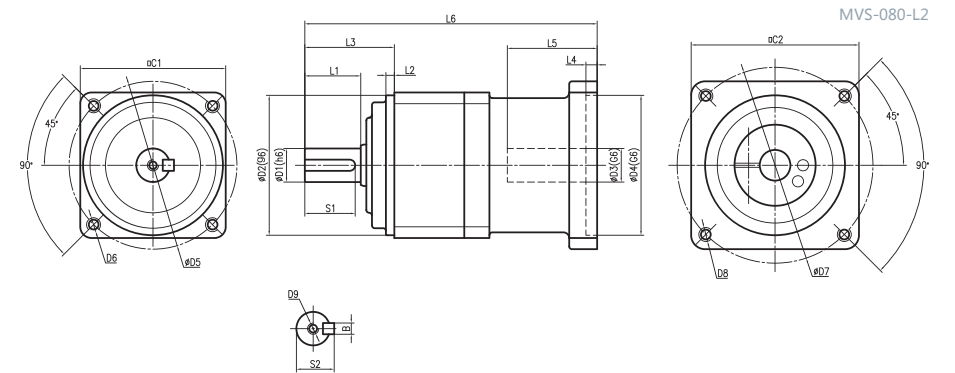

Flange	D1	D2	D3*	D4*	D5	D6	D7*	D8*	D9	L1	L2	L3	L4*	L5*	L6*	C1	C2*	S1	S2	B
Type I	Φ19	Φ70	Φ8	Φ50	Φ90	4-M6	Φ30	4-M4	M6X15	30	3	50	4	32	150	78	60	25	21.5	6
Type II	Φ19	Φ70	Φ14	Φ50	Φ90	4-M6	Φ50	4-M4	M6X15	30	3	50	4	32	150	78	60	25	21.5	6
Type III	Φ19	Φ70	Φ19	Φ70	Φ90	4-M6	Φ50	4-M5	M6X15	30	3	50	4	42	161	78	80	25	21.5	6

\*Dimensions based on servo-motor, please contact us for custom made order.  
注有 \* 尺寸：代表可根据客户需求定制产品，如有需要，请联系我们！

\*Dimensions based on servo-motor, please contact us for custom made order.  
注有 \* 尺寸：代表可根据客户需求定制产品，如有需要，请联系我们！

MVS-100-L1

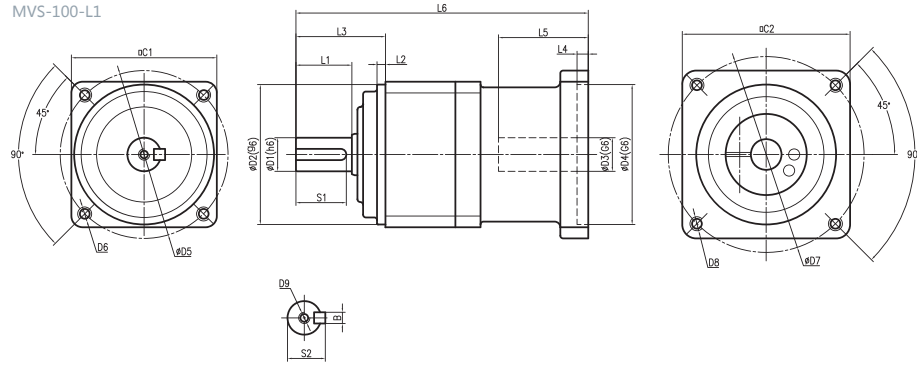

Flange	D1	D2	D3*	D4*	D5	D6	D7*	D8*	D9	L1	L2	L3	L4*	L5*	L6*	C1	C2*	S1	S2	B
Type I	Φ24	Φ90	Φ19	Φ70	Φ115	4-M8	Φ90	4-M5	M8X20	40	5	61	4	50	166	98	80	32	27	6
Type II	Φ24	Φ90	Φ22	Φ110	Φ115	4-M8	Φ145	4-M8	M8X20	40	5	61	10	61	177	98	130	32	27	6
Type III	Φ24	Φ90	Φ24	Φ110	Φ115	4-M8	Φ145	4-M8	M8X20	40	5	61	10	61	177	98	130	32	27	6

MVS-125-L1

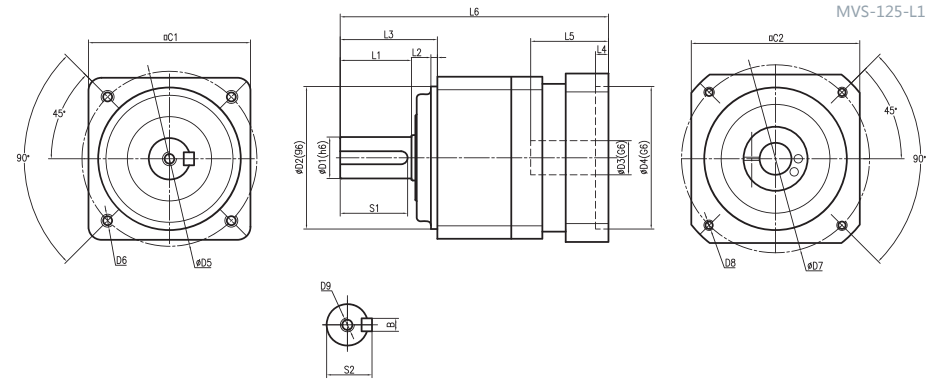

Flange	D1	D2	D3*	D4*	D5	D6	D7*	D8*	D9	L1	L2	L3	L4*	L5*	L6*	C1	C2*	S1	S2	B
Type I	Φ32	Φ110	Φ22	Φ110	Φ135	4-M10X20	Φ145	4-M8X15	M12X22	55	5	75	10	67	214	125	125	52	35	10
Type II	Φ32	Φ110	Φ24	Φ110	Φ135	4-M10X20	Φ145	4-M8X15	M12X22	55	5	75	10	67	214	125	130	52	35	10

MVS-100-L2

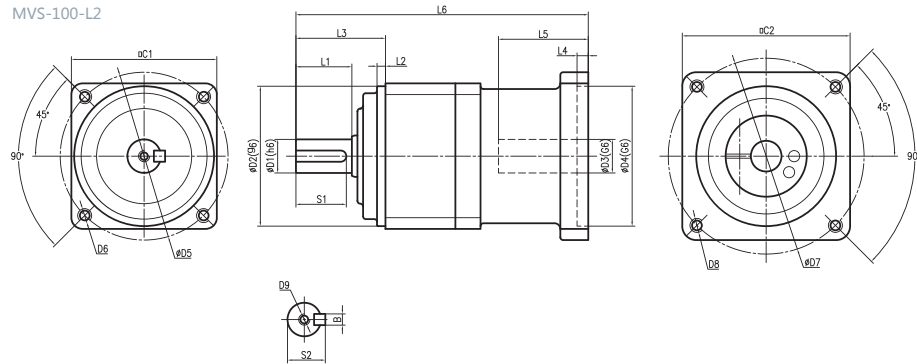

Flange	D1	D2	D3*	D4*	D5	D6	D7*	D8*	D9	L1	L2	L3	L4*	L5*	L6*	C1	C2*	S1	S2	B
Type I	Φ24	Φ90	Φ19	Φ70	Φ115	4-M8	Φ90	4-M6	M8X20	40	5	61	4	43	178	98	80	32	27	8
Type II	Φ24	Φ90	Φ22	Φ110	Φ115	4-M8	Φ145	4-M8	M8X20	40	5	61	10	61	189	98	130	32	27	8
Type III	Φ24	Φ90	Φ24	Φ110	Φ115	4-M8	Φ145	4-M8	M8X20	40	5	61	10	61	189	98	130	32	27	8

MVS-125-L2

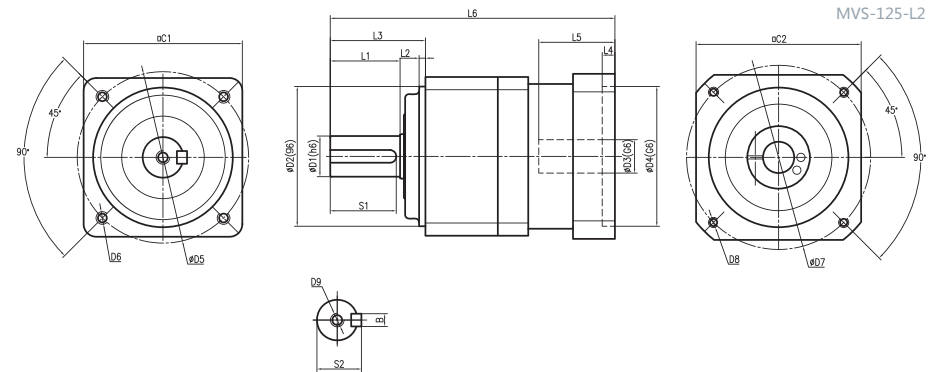

Flange	D1	D2	D3*	D4*	D5	D6	D7*	D8*	D9	L1	L2	L3	L4*	L5*	L6*	C1	C2*	S1	S2	B
Type I	Φ32	Φ110	Φ22	Φ110	Φ135	4-M10X20	Φ145	4-M8X15	M12X22	55	5	75	10	61.5	246.5	125	125	52	35	10
Type II	Φ32	Φ110	Φ24	Φ110	Φ135	4-M10X20	Φ145	4-M8X15	M12X22	55	5	75	10	61.5	246.5	125	130	52	35	10

\*Dimensions based on servo-motor, please contact us for custom made order.  
注有 \* 尺寸：代表可根据客户需求定制产品，如有需要，请联系我们！

\*Dimensions based on servo-motor, please contact us for custom made order.  
注有 \* 尺寸：代表可根据客户需求定制产品，如有需要，请联系我们！

MVS-060																	
Symb.	i	T <sub>2N</sub>	T <sub>2Not</sub>	n <sub>1N</sub>	n <sub>1Max</sub>	j <sub>i</sub>	C <sub>2t</sub>	F <sub>2RMax</sub>	F <sub>2AMax</sub>	J <sub>1</sub>	η	L <sub>h</sub>	T	Lub	PC	MP	dB
Unit		N <sub>m</sub>	N <sub>m</sub>	rpm	rpm	arcmin	Nm/arcmin	N	N	kgcm <sup>2</sup>	%	h	°C				
I STAGE	3	5.2	26	4000	8000	P3 ≤ Stand 标准	0.58	230	200	0.04	≥95	>20000	-15~45	Life Lubrication 终身润滑	IP65	Any 任何方向	≤73
	5	5.7	26				0.58										
	7	5.7	26				0.58										
	9	5.2	26				0.52										
	10	5.2	26				0.52										
II STAGE	12	5.2	26				0.58										
	15	5.2	26				0.58										
	20	5.2	26				0.58										
	25	5.7	26				0.58										
	35	5.7	26				0.58										
	45	5.7	26	0.58													
	50	5.7	26	0.58													
	70	5.7	26	0.58													
	81	5.7	26	0.58													
	100	5.7	26	0.58													

MVS-100																		
Symb.	i	T <sub>2N</sub>	T <sub>2Not</sub>	n <sub>1N</sub>	n <sub>1Max</sub>	j <sub>i</sub>	C <sub>2t</sub>	F <sub>2RMax</sub>	F <sub>2AMax</sub>	J <sub>1</sub>	η	L <sub>h</sub>	T	Lub	PC	MP	dB	
Unit		N <sub>m</sub>	N <sub>m</sub>	rpm	rpm	arcmin	Nm/arcmin	N	N	kgcm <sup>2</sup>	%	h	°C					
I STAGE	3	100	480	2600	4800	P3 ≤ Stand 标准	16.5	2000	1000	1.8	≥95	>20000	-15~45	Life Lubrication 终身润滑	IP65	Any 任何方向	≤75	
	5	100	480															16.5
	7	100	480															16.5
	9	90	480															16.5
	10	90	480															16.5
II STAGE	12	100	480															16.5
	15	100	480															16.5
	20	100	480															16.5
	25	100	480															16.5
	35	100	480															16.5
	45	100	480	16.5														
	50	100	480	16.5														
	70	100	480	16.5														
	81	100	480	16.5														
	100	100	480	16.5														

MVS-080																	
Symb.	i	T <sub>2N</sub>	T <sub>2Not</sub>	n <sub>1N</sub>	n <sub>1Max</sub>	j <sub>i</sub>	C <sub>2t</sub>	F <sub>2RMax</sub>	F <sub>2AMax</sub>	J <sub>1</sub>	η	L <sub>h</sub>	T	Lub	PC	MP	dB
Unit		N <sub>m</sub>	N <sub>m</sub>	rpm	rpm	arcmin	Nm/arcmin	N	N	kgcm <sup>2</sup>	%	h	°C				
I STAGE	3	40	190	3400	6000	P3 ≤ Stand 标准	6.1	1600	1200	0.54	≥95	>20000	-15~45	Life Lubrication 终身润滑	IP65	Any 任何方向	≤73
	5	40	190				6.1										
	7	35	190				5.5										
	9	40	190				6.1										
	10	40	190				6.1										
II STAGE	12	40	190				6.1										
	15	40	190				6.1										
	20	40	190				6.1										
	25	40	190				6.1										
	35	35	190				5.5										
	45	35	190	5.5													
	50	40	190	6.1													
	70	40	190	6.1													
	81	40	190	6.1													
	100	40	190	6.1													

MVS-125																	
Symb.	i	T <sub>2N</sub>	T <sub>2Not</sub>	n <sub>1N</sub>	n <sub>1Max</sub>	j <sub>i</sub>	C <sub>2t</sub>	F <sub>2RMax</sub>	F <sub>2AMax</sub>	J <sub>1</sub>	η	L <sub>h</sub>	T	Lub	PC	MP	dB
Unit		N <sub>m</sub>	N <sub>m</sub>	rpm	rpm	arcmin	Nm/arcmin	N	N	kgcm <sup>2</sup>	%	h	°C				
I STAGE	3	208	624	2000	4000	P3 ≤ Stand 标准	25	6700	3000	3.25	≥95	>20000	-15~45	Life Lubrication 终身润滑	IP65	Any 任何方向	≤80
	4	290	870				25										
	5	330	990				25										
	7	300	900				25										
	10	230	690				25										
II STAGE	15	208	624				25										
	16	220	660				25										
	20	290	870				25										
	25	330	990				25										
	30	310	930				25										
	35	300	900	25													
	40	260	780	25													
	50	330	990	25													
	70	300	900	25													
	100	230	690	25													

MVS

MVS

**Efficiency**

The efficiency of planetary reducers varies with several parameters such as ratio, input speed, temperature, lubrication conditions, etc.

The efficiency was measured under the following working conditions:

Input speed ( rpm )	3000
Operating temperature ( °C )	25
Lubricant	Standard

**效率特性**

减速机的效率一般因减速比、输入转速、负载转速、温度、润滑条件而异。在下列测定条件下，各系列的效率如下所示。此外，图表的数值均为平均值。

输入转速 (rpm)	3000
环境温度 ( °C )	25
润滑剂	标准润滑剂

