



高性能系列适应于最恶劣工况。MAF精密行星提供高刚性、最大扭矩、最高精度和小体积。

High-performance series for heaviest operating duties, MAF gearboxes present high torsional stiffness, maximum power, optimum precision and compactness.



造型数据:
Selection data:

扭矩 (Nm)	35-2300
速比	4-100
背隙 (arcmin)	3-5
最大工作温度 (°C)	90
噪音 (dB)	60-75

Nominal output torque (Nm)	35-2300
Reduction ratio	4-100
Backlash (arcmin)	3-5
Max.working temperature (°C)	90
Noise (dB)	60-75

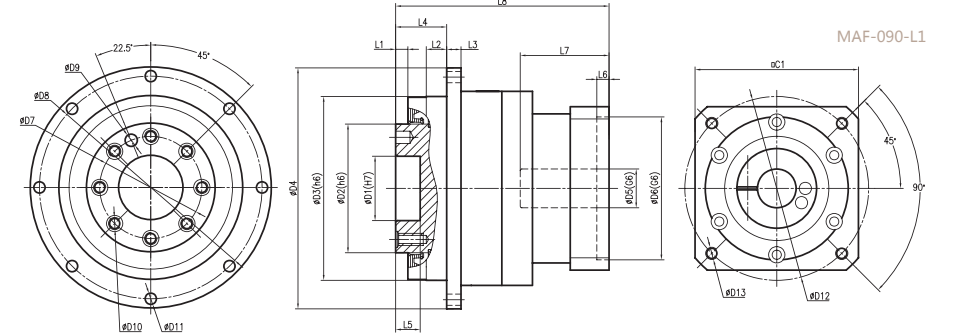
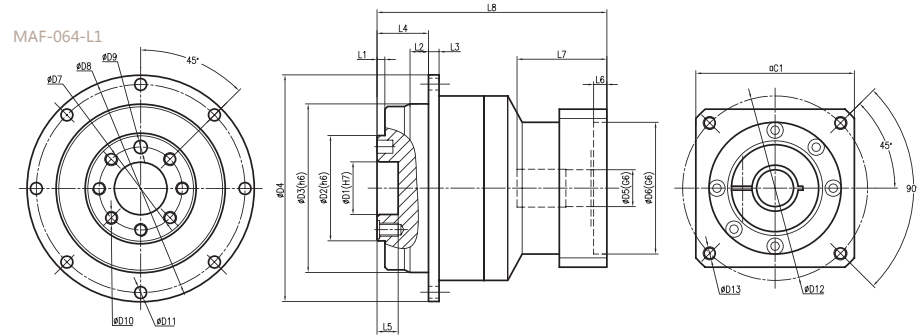

Flange	D1	D2	D3	D4	D5*	D6*	D7	D8	D9	D10	D11	D12*	D13*	L1	L2	L3	L4	L5	L6*	L7*	L8*	C1*
Type I	Φ20	Φ40	Φ64	Φ86	Φ8	Φ30	Φ31.5	Φ79	Φ5X8	7-M5X8	8-Φ4.5	Φ46	4-M4X8	3	7	4	19.5	8	4	28	80.5	40
Type II	Φ20	Φ40	Φ64	Φ86	Φ11	Φ50	Φ31.5	Φ79	Φ5X8	7-M5X8	8-Φ4.5	Φ70	4-M4X8	3	7	4	19.5	8	5	34	87	60
Type III	Φ20	Φ40	Φ64	Φ86	Φ14	Φ50	Φ31.5	Φ79	Φ5X8	7-M5X8	8-Φ4.5	Φ70	4-M5X10	3	7	4	19.5	8	5	34	87	60

Flange	D1	D2	D3	D4	D5*	D6*	D7	D8	D9	D10	D11	D12*	D13*	L1	L2	L3	L4	L5	L6*	L7*	L8*	C1*
Type I	Φ31.5	Φ63	Φ90	Φ118	Φ14	Φ50	Φ50	Φ109	Φ6X7	8-M6X12	8-Φ5.5	Φ70	4-M5X10	6	10	7	30	12	5	32	97	60
Type II	Φ31.5	Φ63	Φ90	Φ118	Φ19	Φ70	Φ50	Φ109	Φ6X7	8-M6X12	8-Φ5.5	Φ90	4-M6X12	6	10	7	30	12	6	43.5	104.5	80
Type III	Φ31.5	Φ63	Φ90	Φ118	Φ22	Φ110	Φ50	Φ109	Φ6X7	8-M6X12	8-Φ5.5	Φ145	4-M8X16	6	10	7	30	12	10	59	120	130

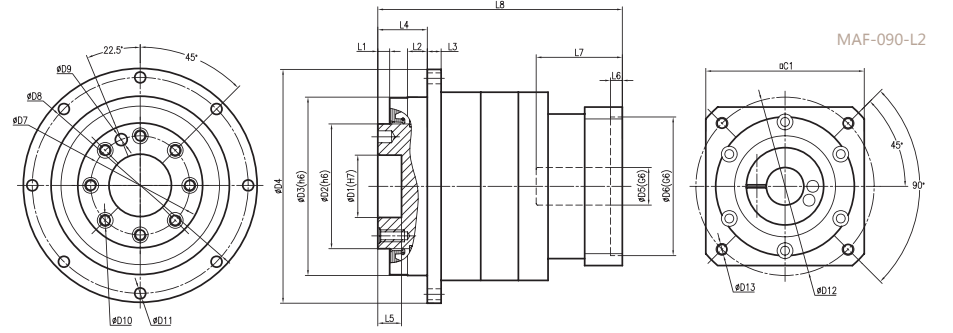
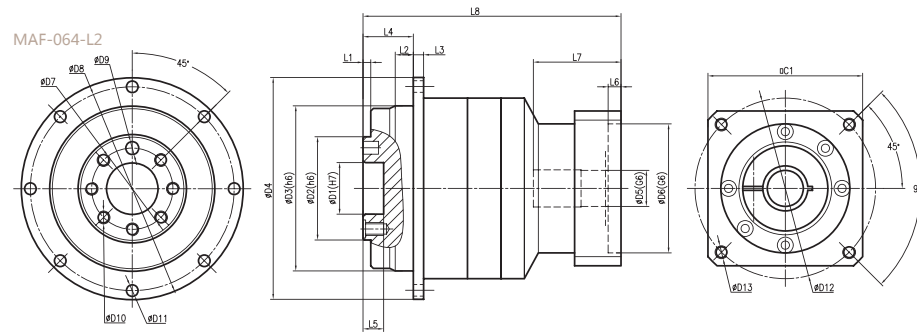

Flange	D1	D2	D3	D4	D5*	D6*	D7	D8	D9	D10	D11	D12*	D13*	L1	L2	L3	L4	L5	L6*	L7*	L8*	C1*
Type I	Φ20	Φ40	Φ64	Φ86	Φ8	Φ30	Φ31.5	Φ79	Φ5X8	7-M5X8	8-Φ4.5	Φ46	4-M4X8	3	7	4	19.5	8	4	28	103	40
Type II	Φ20	Φ40	Φ64	Φ86	Φ11	Φ50	Φ31.5	Φ79	Φ5X8	7-M5X8	8-Φ4.5	Φ70	4-M4X8	3	7	4	19.5	8	5	34	110.5	60
Type III	Φ20	Φ40	Φ64	Φ86	Φ14	Φ50	Φ31.5	Φ79	Φ5X8	7-M5X8	8-Φ4.5	Φ70	4-M5X10	3	7	4	19.5	8	5	34	110.5	60

Flange	D1	D2	D3	D4	D5*	D6*	D7	D8	D9	D10	D11	D12*	D13*	L1	L2	L3	L4	L5	L6*	L7*	L8*	C1*
Type I	Φ31.5	Φ63	Φ90	Φ118	Φ14	Φ50	Φ50	Φ109	Φ6X7	8-M6X12	8-Φ5.5	Φ70	4-M5X10	6	10	7	30	12	5	34	123	60
Type II	Φ31.5	Φ63	Φ90	Φ118	Φ19	Φ70	Φ50	Φ109	Φ6X7	8-M6X12	8-Φ5.5	Φ90	4-M6X12	6	10	7	30	12	6	43.5	132.5	80
Type III	Φ31.5	Φ63	Φ90	Φ118	Φ22	Φ110	Φ50	Φ109	Φ6X7	8-M6X12	8-Φ5.5	Φ145	4-M8X16	6	10	7	30	12	10	59	139	130

*Dimensions based on servo-motor, please contact us for custom made order.
注有 * 尺寸：代表可根据客户需求定制产品，如有需要，请联系我们！

*Dimensions based on servo-motor, please contact us for custom made order.
注有 * 尺寸：代表可根据客户需求定制产品，如有需要，请联系我们！

MAF-110-L1

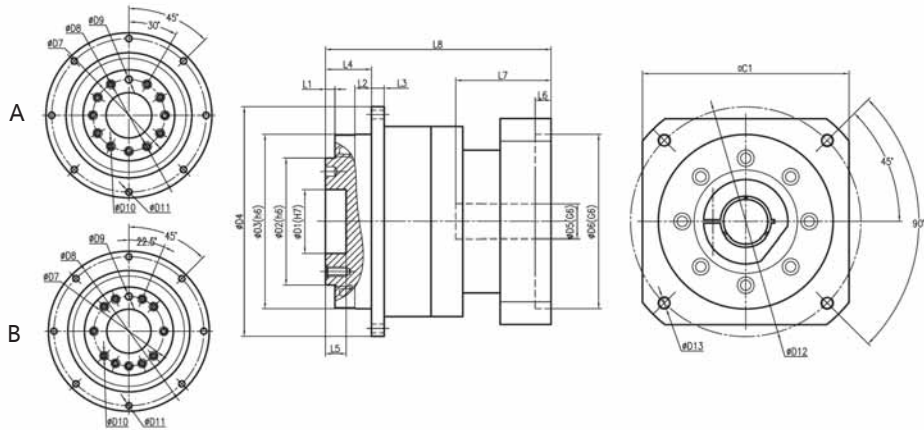

Flange	D1	D2	D3	D4	D5*	D6*	D7	D8	D9	D10	D11	D12*	D13*	L1	L2	L3	L4	L5	L6*	L7*	L8*	C1*
Type I	Φ40	Φ80	Φ110	Φ145	Φ22	Φ110	Φ63	Φ135	Φ6X7	11-M6X12	8-Φ5.5	Φ145	4-M8X15	6	10	8	29	13	10	60	142	130
Type II	Φ40	Φ80	Φ110	Φ145	Φ24	Φ110	Φ63	Φ135	Φ6X7	11-M6X12	8-Φ5.5	Φ145	4-M8X15	6	10	8	29	13	10	60	142	130
Type III	Φ40	Φ80	Φ110	Φ145	Φ28	Φ110	Φ63	Φ135	Φ6X7	11-M6X12	8-Φ5.5	Φ145	4-M8X15	6	10	8	29	13	10	60	142	130

MAF-110-L2

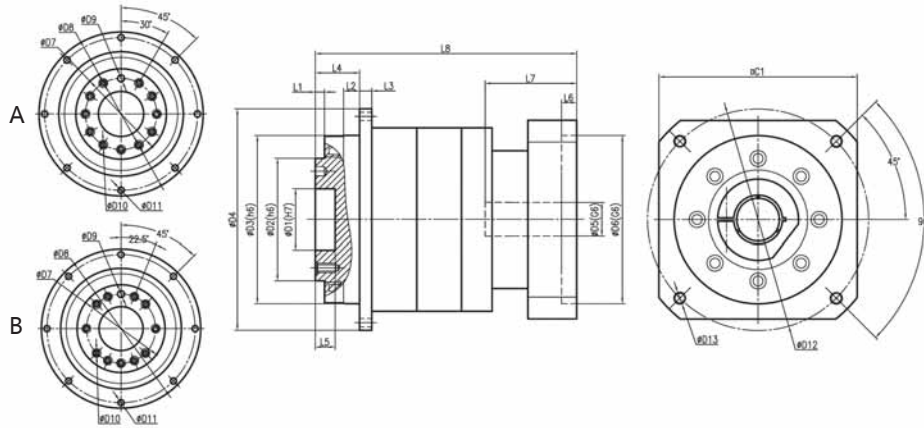

Flange	D1	D2	D3	D4	D5*	D6*	D7	D8	D9	D10	D11	D12*	D13*	L1	L2	L3	L4	L5	L6*	L7*	L8*	C1*
Type I	Φ40	Φ80	Φ110	Φ145	Φ19	Φ70	Φ63	Φ135	Φ6X7	11-M6X12	8-Φ5.5	Φ90	4-M6X12	6	10	8	29	13	6	435	1515	80
Type II	Φ40	Φ80	Φ110	Φ145	Φ22	Φ110	Φ63	Φ135	Φ6X7	11-M6X12	8-Φ5.5	Φ145	4-M8X15	6	10	8	29	13	10	60	176	130
Type III	Φ40	Φ80	Φ110	Φ145	Φ24	Φ110	Φ63	Φ135	Φ6X7	11-M6X12	8-Φ5.5	Φ145	4-M8X15	6	10	8	29	13	10	60	176	130
Type IV	Φ40	Φ80	Φ110	Φ145	Φ28	Φ110	Φ63	Φ135	Φ6X7	11-M6X12	8-Φ5.5	Φ145	4-M8X15	6	10	8	29	13	10	60	176	130

MAF-140-L1

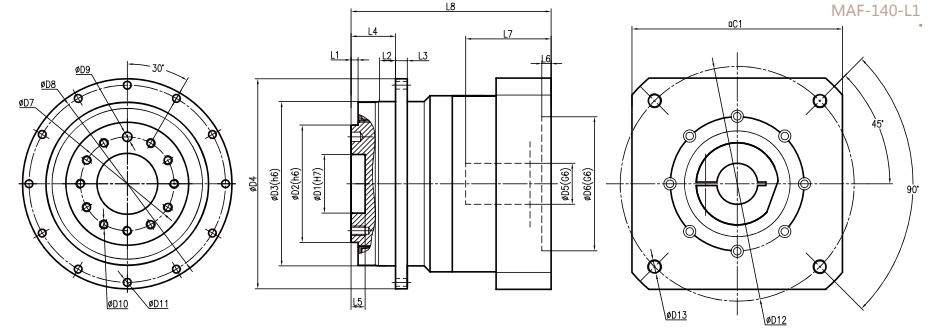

Flange	D1	D2	D3	D4	D5*	D6*	D7	D8	D9	D10	D11	D12*	D13*	L1	L2	L3	L4	L5*	L6*	L7*	L8*	C1*
Type I	Φ50	Φ100	Φ140	Φ179	Φ24	Φ110	Φ80	Φ168	Φ8X7	11-M8X17	12-Φ6.6	Φ145	4-M8X15	6	14.5	10	38	12	6	73	159	130
Type II	Φ50	Φ100	Φ140	Φ179	Φ38	Φ114.3	Φ80	Φ168	Φ8X7	11-M8X17	12-Φ6.6	Φ200	4-M12X25	6	14.5	10	38	12	8	85	171	180
Type III	Φ50	Φ100	Φ140	Φ179	Φ48	Φ114.3	Φ80	Φ168	Φ8X7	11-M8X17	12-Φ6.6	Φ200	4-M12X25	6	14.5	10	38	12	8	115	201	180

MAF-140-L2

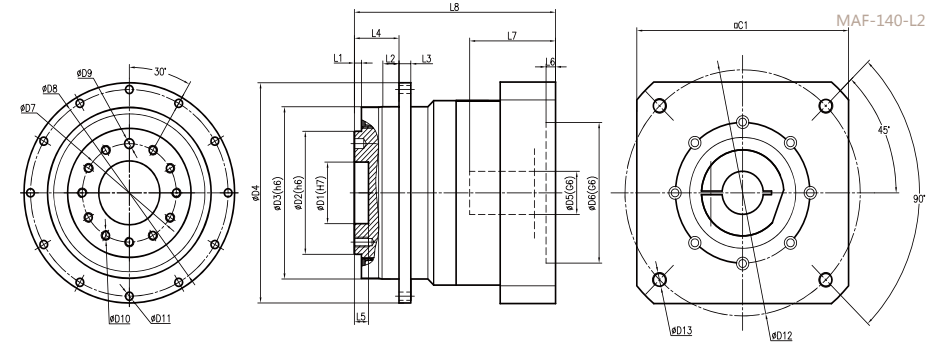

Flange	D1	D2	D3	D4	D5*	D6*	D7	D8	D9	D10	D11	D12*	D13*	L1	L2	L3	L4	L5*	L6*	L7*	L8*	C1*
Type I	Φ50	Φ100	Φ140	Φ179	Φ19	Φ70	Φ80	Φ168	Φ8X7	11-M8X17	12-Φ6.6	Φ90	4-M5X12	6	14.5	10	38	12	6	65	1955	90
Type II	Φ50	Φ100	Φ140	Φ179	Φ24	Φ110	Φ80	Φ168	Φ8X7	11-M8X17	12-Φ6.6	Φ145	4-M8X15	6	14.5	10	38	12	8	73	1995	130
Type III	Φ50	Φ100	Φ140	Φ179	Φ38	Φ114.3	Φ80	Φ168	Φ8X7	11-M8X17	12-Φ6.6	Φ200	4-M12X25	6	14.5	10	38	12	8	85	215	180

*Dimensions based on servo-motor, please contact us for custom made order.
注有 * 尺寸：代表可根据客户需求定制产品，如有需要，请联系我们！

MAF-200-L1

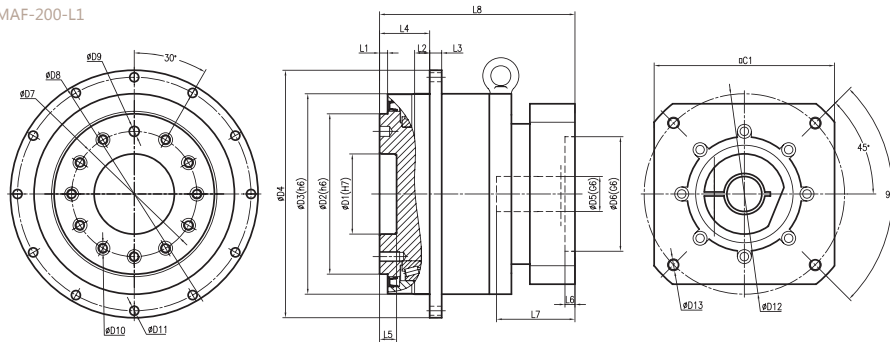

Flange	D1	D2	D3	D4	D5*	D6*	D7	D8	D9	D10	D11	D12*	D13*	L1	L2	L3	L4	L5	L6*	L7*	L8*	C1*
Type I	Φ80	Φ160	Φ200	Φ247	Φ35	Φ114.3	Φ125	Φ233	Φ10X10	11-M10X20	12-Φ9	Φ200	4-M12X25	8	15	12	50	16	10	88	196	180
Type II	Φ80	Φ160	Φ200	Φ247	Φ42	Φ114.3	Φ125	Φ233	Φ10X10	11-M10X20	12-Φ9	Φ200	4-M12X25	8	15	12	50	16	10	115	226	180
Type III	Φ80	Φ160	Φ200	Φ247	Φ48	Φ200	Φ125	Φ233	Φ10X10	11-M10X20	12-Φ9	Φ235	4-M12X25	8	15	12	50	16	10	117	229	220

MAF-255-L1

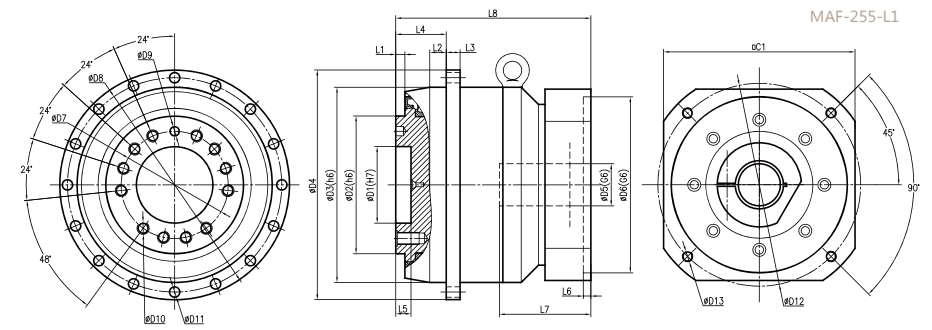

Flange	D1	D2	D3	D4	D5*	D6*	D7	D8	D9	D10	D11	D12*	D13*	L1	L2	L3	L4	L5	L6*	L7*	L8*	C1*
Type I	Φ100	Φ180	Φ255	Φ300	Φ48	Φ200	Φ140	Φ280	Φ12X10	12-M16X25	16-Φ13.5	Φ235	4-M12X25	12	21.5	18	66	20	10	119.5	255	220
Type II	Φ100	Φ180	Φ255	Φ300	Φ55	Φ200	Φ140	Φ280	Φ12X10	12-M16X25	16-Φ13.5	Φ235	4-M12X25	12	21.5	18	66	20	10	119.5	255	220

MAF-200-L2

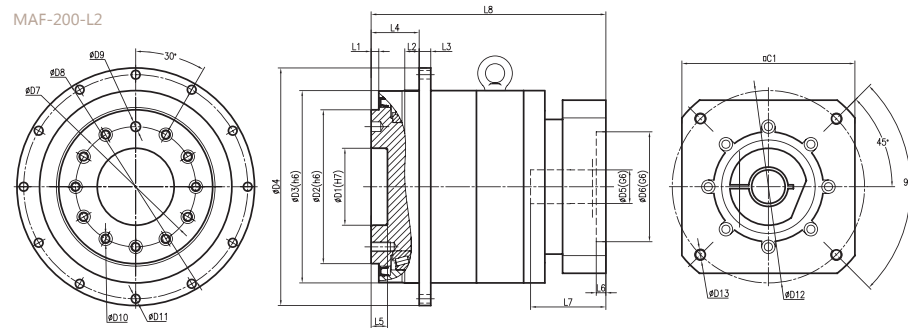

Flange	D1	D2	D3	D4	D5*	D6*	D7	D8	D9	D10	D11	D12*	D13*	L1	L2	L3	L4	L5	L6*	L7*	L8*	C1*
Type I	Φ80	Φ160	Φ200	Φ247	Φ35	Φ114.3	Φ125	Φ233	Φ10X10	11-M10X20	12-Φ9	Φ200	4-M12X25	8	15	12	50	16	10	83	247.5	180
Type II	Φ80	Φ160	Φ200	Φ247	Φ42	Φ114.3	Φ125	Φ233	Φ10X10	11-M10X20	12-Φ9	Φ200	4-M12X25	8	15	12	50	16	10	115	277.5	180
Type III	Φ80	Φ160	Φ200	Φ247	Φ48	Φ200	Φ125	Φ233	Φ10X10	11-M10X20	12-Φ9	Φ235	4-M12X25	8	15	12	50	16	10	117	280	220

MAF-255-L2

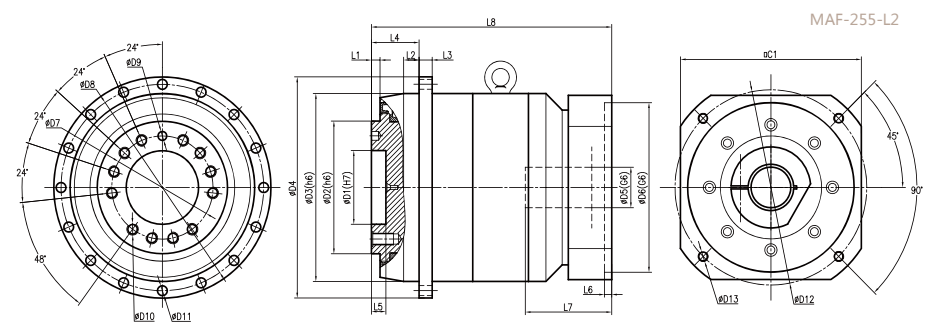

Flange	D1	D2	D3	D4	D5*	D6*	D7	D8	D9	D10	D11	D12*	D13*	L1	L2	L3	L4	L5	L6*	L7*	L8*	C1*
Type I	Φ100	Φ180	Φ255	Φ300	Φ35	Φ114.3	Φ140	Φ280	Φ12X10	12-M16X25	16-Φ13.5	Φ200	4-M12X25	12	20	18	66	20	6	73	295	180
Type II	Φ100	Φ180	Φ255	Φ300	Φ48	Φ200	Φ140	Φ280	Φ12X10	12-M16X25	16-Φ13.5	Φ235	4-M12X25	12	20	18	66	20	10	117	330	220
Type III	Φ100	Φ180	Φ255	Φ300	Φ55	Φ200	Φ140	Φ280	Φ12X10	12-M16X25	16-Φ13.5	Φ235	4-M12X25	12	20	18	66	20	10	117	330	220

*Dimensions based on servo-motor, please contact us for custom made order.
注有 * 尺寸：代表可根据客户需求定制产品，如有需要，请联系我们！

*Dimensions based on servo-motor, please contact us for custom made order.
注有 * 尺寸：代表可根据客户需求定制产品，如有需要，请联系我们！

MAF-064																		
Symb.	i	T _{2N}	T _{2Not}	n _{1N}	n _{1Max}	j _t	C _{2t}	F _{2NMax}	F _{2MMax}	J ₁	η	L _h	T	Lub	PC	MP	dB	
Unit		N _m	N _m	rpm	rpm	arcmin	N _{inYarcmin}	N	N	kgcm ²	%	h	°C					
I STAGE	4	50								0.13	≥95			Life Lubrication 终身润滑	IP65	Any 任何方向	≤60	
	5	50								0.13								
	6	50								0.13								
	7	50								0.13								
	8	50								0.03								
	9	35								0.03								
	10	35								0.03								
	20	50	2×T _{2N}	3300	6000		13	1300	680									0.03
	25	50								0.03								
	50	50								0.03								
II STAGE	20	50								0.03	≥90			Life Lubrication 终身润滑	IP65	Any 任何方向	≤60	
	25	50								0.03								
	50	50								0.03								
	80	50								0.03								
	100	35								0.03								

MAF-110																		
Symb.	i	T _{2N}	T _{2Not}	n _{1N}	n _{1Max}	j _t	C _{2t}	F _{2NMax}	F _{2MMax}	J ₁	η	L _h	T	Lub	PC	MP	dB	
Unit		N _m	N _m	rpm	rpm	arcmin	N _{inYarcmin}	N	N	kgcm ²	%	h	°C					
I STAGE	4	300								2.87	≥95			Life Lubrication 终身润滑	IP65	Any 任何方向	≤65	
	5	350								2.71								
	6	360								2.71								
	7	350								2.62								
	8	360								2.61								
	9	240								2.58								
	10	220								2.57								
	20	300	2×T _{2N}	2300	6000													0.47
	25	350								0.47								
	50	350								0.44								
II STAGE	20	300								0.47	≥90			Life Lubrication 终身润滑	IP65	Any 任何方向	≤65	
	25	350								0.47								
	50	350								0.44								
	80	350								0.44								
	100	220								0.44								

MAF-090																		
Symb.	i	T _{2N}	T _{2Not}	n _{1N}	n _{1Max}	j _t	C _{2t}	F _{2NMax}	F _{2MMax}	J ₁	η	L _h	T	Lub	PC	MP	dB	
Unit		N _m	N _m	rpm	rpm	arcmin	N _{inYarcmin}	N	N	kgcm ²	%	h	°C					
I STAGE	4	120								0.51	≥95			Life Lubrication 终身润滑	IP65	Any 任何方向	≤63	
	5	125								0.47								
	6	125								0.47								
	7	125								0.45								
	8	125								0.45								
	9	80								0.44								
	10	80								0.44								
	20	120	2×T _{2N}	2600	6000		31	3100	1650									0.13
	25	125								0.13								
	50	125								0.13								
II STAGE	20	120								0.13	≥90			Life Lubrication 终身润滑	IP65	Any 任何方向	≤63	
	25	125								0.13								
	50	125								0.13								
	80	125								0.44								
	100	80								0.13								

MAF-140																		
Symb.	i	T _{2N}	T _{2Not}	n _{1N}	n _{1Max}	j _t	C _{2t}	F _{2NMax}	F _{2MMax}	J ₁	η	L _h	T	Lub	PC	MP	dB	
Unit		N _m	N _m	rpm	rpm	arcmin	N _{inYarcmin}	N	N	kgcm ²	%	h	°C					
I STAGE	4	650								7.54	≥95			Life Lubrication 终身润滑	IP65	Any 任何方向	≤66	
	5	700								7.42								
	6	700								7.42								
	7	700								7.14								
	8	700								7.13								
	9	500								7.08								
	10	460								7.03								
	20	650	2×T _{2N}	2000	5000													2.71
	25	700								2.71								
	50	700								2.57								
II STAGE	20	650								2.71	≥90			Life Lubrication 终身润滑	IP65	Any 任何方向	≤66	
	25	700								2.71								
	50	700								2.57								
	80	700								2.57								
	100	460								2.57								

MAF-200																	
Symb.	i	T _{2N}	T _{2Not}	n _{1N}	n _{1Max}	j _t	C _{2t}	F _{2RM}	F _{2M}	J ₁	η	L _n	T	Lub	PC	MP	dB
Unit		N _m	N _m	rpm	rpm	arcmin	N _m /rpm	N	N	kg _{cm} ²	%	h	°C				
I STAGE	4	1350	2×T _{2N}	2000	4000	≤3	450	18520	15500	23.4	≥95	>20000	-15~45	Life Lubrication 终身润滑	IP65	Any 任何方向	≤73
	5	1400								23.4							
	6	1400								23.4							
	7	1400								23.4							
	8	1400								21.8							
	9	980								21.8							
II STAGE	20	1350	21.8														
	25	1400	21.8														
	50	1400	21.8														
	80	1400	21.8														
	100	980	21.8														

MAF-255																	
Symb.	i	T _{2N}	T _{2Not}	n _{1N}	n _{1Max}	j _t	C _{2t}	F _{2RM}	F _{2M}	J ₁	η	L _n	T	Lub	PC	MP	dB
Unit		N _m	N _m	rpm	rpm	arcmin	N _m /rpm	N	N	kg _{cm} ²	%	h	°C				
I STAGE	4	2200	2×T _{2N}	2000	3000	≤3	1023	27000	24000	64.3	≥95	>20000	-15~45	Life Lubrication 终身润滑	IP65	Any 任何方向	≤77
	5	2300								64.3							
	6	2300								64.3							
	7	2300								64.3							
	8	2300								64.3							
	9	1800								64.3							
II STAGE	10	1600	23.4														
	20	2200	23.4														
	25	2300	23.4														
	50	2300	23.4														
	80	2300	23.4														

Efficiency

The efficiency of planetary reducers varies with several parameters such as ratio, input speed, temperature, lubrication conditions, etc.

The efficiency was measured under the following working conditions:

Input speed (rpm)	3000
Operating temperature (°C)	25
Lubricant	Standard

效率特性

减速机的效率一般因减速比、输入转速、负载转速、温度、润滑条件而异。在下列测定条件下，各系列的效率如下所示。此外，图表的数值均为平均值。

输入转速 (rpm)	3000
环境温度 (°C)	25
润滑剂	标准润滑剂

